

THE BIOTECHNOLOGY
EDUCATION COMPANY®

REVISED
&
UPDATED

Edvo-Kit #
372

Edvo-Kit #372

Quick PCR

Experiment Objective:

In this experiment, students will gain an understanding of the traditional three-step Polymerase Chain Reaction (PCR). Using PCR and Agarose Gel Electrophoresis, they will analyze a small section of Lambda DNA in a time-saving two-step process.

See page 3 for storage instructions.

LyphoTemplate™

LyphoPrimer™



NOTE:

PCR Cycling Conditions have changed. Please review your PCR program before performing the experiment.

Table of Contents

	Page
Experiment Components	3
Experiment Requirements	4
Background Information	5
Experiment Procedures	
Experiment Overview	8
Module I: Amplification of Lambda DNA	9
Overview of Agarose Gel Electrophoresis & Staining	10
Module II-A: Separation of PCR Products by Electrophoresis (SYBR® Safe Stain)	11
Module II-B: Separation of PCR Products by Electrophoresis (Improved FlashBlue™ Staining)	14
Study Questions	17
Instructor's Guidelines	18
Pre-Lab Preparations	19
Experiment Results and Analysis	22
Study Questions and Answers	23
Appendices	24
A EDVOTEK® Troubleshooting Guide	25
B Performing the PCR Experiment Using Two Waterbaths	26
C Bulk Preparation of Electrophoresis Buffer and Agarose Gels	27

Safety Data Sheets can be found on our website: www.edvotek.com/safety-data-sheets

EDVO-TECH Service

1.800.EDVOTEK

Mon. - Fri. 8am-5:30pm EST



Please Have the Following Info:

- Product Number & Description
- Lot Number on Box
- Order/Purchase Order #
- Approx. Purchase Date

Fax: 202.370.1501 • info@edvotek.com • www.edvotek.com

www.edvotek.com

- Online Catalog
- Order Products
- Experiment Protocols
- Tech Support
- Resources!



1.800.EDVOTEK • Fax 202.370.1501 • info@edvotek.com • www.edvotek.com

Duplication of any part of this document is permitted for non-profit educational purposes only. Copyright © 1989-2019 EDVOTEK, Inc., all rights reserved. 372.190123

Experiment Components

Components	Storage	Check (✓)
A LyphoPrimer™ Mix	-20° C	<input type="checkbox"/>
B EdvoQuick™ DNA ladder	-20° C	<input type="checkbox"/>
C LyphoTemplate™ Lambda DNA	-20° C	<input type="checkbox"/>
D TE Buffer	-20° C	<input type="checkbox"/>
• PCR EdvoBeads™	Room Temp.	<input type="checkbox"/>

(Each PCR EdvoBead™ contains: dNTP Mixture, Taq DNA Polymerase Buffer, Taq DNA Polymerase, MgCl₂, and Reaction Buffer)

NOTE: Components A and C are supplied in our LyphoPrimer™ and LyphoTemplate™ format. They will require reconstitution before use. Be sure to review page 19 in the Instructor's Guide for more details.

This experiment is designed for 10 lab groups.

All experiment components are intended for educational research only. They are not to be used for diagnostic or drug purposes, nor administered to or consumed by humans or animals.

REAGENTS & SUPPLIES

Store all components below at room temperature.

Component	Check (✓)
• UltraSpec-Agarose™	<input type="checkbox"/>
• Electrophoresis Buffer (50X)	<input type="checkbox"/>
• SYBR® Safe Stain	<input type="checkbox"/>
• FlashBlue™ Stain	<input type="checkbox"/>
• Microcentrifuge Tubes	<input type="checkbox"/>
• PCR Tubes	<input type="checkbox"/>

LyphoTemplate™

LyphoPrimer™



NOTE: PCR Cycling Conditions have changed. Please review your PCR program before performing the experiment.

EDVOTEK and The Biotechnology Education Company are registered trademarks of EDVOTEK, Inc. SYBR is a registered trademark of Thermo Fisher Scientific. EdvoBead, UltraSpec-Agarose, LyphoPrimer, LyphoTemplate, EdvoQuick, and FlashBlue are trademarks of EDVOTEK, Inc.

1.800.EDVOTEK • Fax 202.370.1501 • info@edvotek.com • www.edvotek.com

Duplication of any part of this document is permitted for non-profit educational purposes only. Copyright © 1989-2019 EDVOTEK, Inc., all rights reserved. 372.190123



Requirements

- Thermal cycler (EDVOTEK Cat. # 541 highly recommended) or two waterbaths*
- Horizontal gel electrophoresis apparatus
- D.C. power supply
- Microcentrifuge
- UV Transilluminator or Blue light visualization (use if staining with SYBR® Safe)
- UV safety goggles (use if staining with SYBR® Safe)
- White light visualization system (use if staining with FlashBlue™)
- Automatic micropipettes (5-50 µL) with tips
- Microwave
- Pipet pump
- 250 mL flasks or beakers
- Hot gloves
- Disposable laboratory gloves
- Ice buckets and ice
- Distilled or deionized water

**If you do not have a thermal cycler, this experiment can be conducted using three water baths with proper care (EDVOTEK® Cat. #544 highly recommended). However, a thermal cycler assures a significantly higher rate of success. See Appendix B for detailed instructions.*



Background Information

THE POLYMERASE CHAIN REACTION

In 1984, Dr. Kary Mullis revolutionized the field of molecular biology when he devised a simple and elegant method to copy specific pieces of DNA. Mullis recognized that he could replicate DNA *in vitro* using short, synthetic DNA oligonucleotides (known as primers) and DNA polymerase I in a process similar to DNA replication in a cell's nucleus. Because researchers can customize the primers to target a specific gene, this method allows for the rapid amplification of a selected DNA sequence. For the development of this technique, known today as the Polymerase Chain Reaction (or PCR), Mullis was awarded the Nobel Prize in Chemistry in 1993.

Before performing PCR, template DNA is extracted from a biological sample. Two primers are designed to correspond to the 5' and 3' ends of the target sequence. The template DNA and primers are mixed with buffer, the four "free" deoxynucleotides (dATP, dCTP, dGTP, and dTTP), and a thermostable DNA polymerase (*Taq*). Next, the PCR mixture is subjected to sequential heating/cooling cycles at three different temperatures to amplify DNA.

- In the first step, known as "denaturation", the mixture is heated to 94° C to disrupt the hydrogen bonds between the complementarity strands. This causes the target DNA to unzip into single strands (or melt). It is important to use a thermostable DNA polymerase for PCR because this enzyme remains stable at high temperatures.
- In the second step, known as "annealing", the reaction mixture is cooled to 45° C - 65° C. This allows the primers to base pair with the target DNA sequence.
- In the third step, known as "extension", the temperature is raised to 72° C. This temperature is optimal for *Taq* polymerase to add nucleotides to the 3' end of the primer, synthesizing a new strand of DNA.

Together, these three steps - denaturation, annealing, and extension - make up one PCR "cycle" (Figure 1). To simplify this process, a specialized machine, called a "thermal cycler" or a "PCR machine", was created to heat and cool the samples rapidly.

Each PCR cycle doubles the amount of the target DNA in less than five minutes. This makes PCR a very sensitive technique, as only a few copies of the template DNA are required to produce a large amount of signal. Mathematically, PCR is described as an exponential relationship - if we begin with a starting copy number of m , then after n cycles, we will have $m \times 2^n$ copies of our DNA target. For example, if we start with one copy of our target, we will have two copies after the first PCR cycle, four after the second PCR cycle, eight after the third PCR cycle, and so on. In numbers, cycle 1 equals 1×2^1 , cycle 2 equals 1×2^2 , cycle 3 equals 1×2^3 . After n cycles, we will have 1×2^n copies of our DNA target. In order to produce enough DNA for analysis, twenty to forty cycles may be required. After many cycles (regardless of the quantity of DNA present in the starting material) the amount of DNA produced reaches a maximum amount of product known as the plateau. This is due to depletion of reaction components like primers and nucleotides and the loss of *Taq* polymerase activity.

Because of its ease of use and its ability to amplify DNA rapidly, PCR has become indispensable in medical and life sciences labs, replacing the time-intensive Southern blot as the method of choice. For example, today's research laboratories can quickly create copies of a specific region of DNA for cloning applications. Medical diagnostics use PCR to identify genetic mutations and infectious agents. In addition, because amplification by PCR requires a small amount of starting material, it is ideal for forensic analysis of biological samples or determination of paternity.

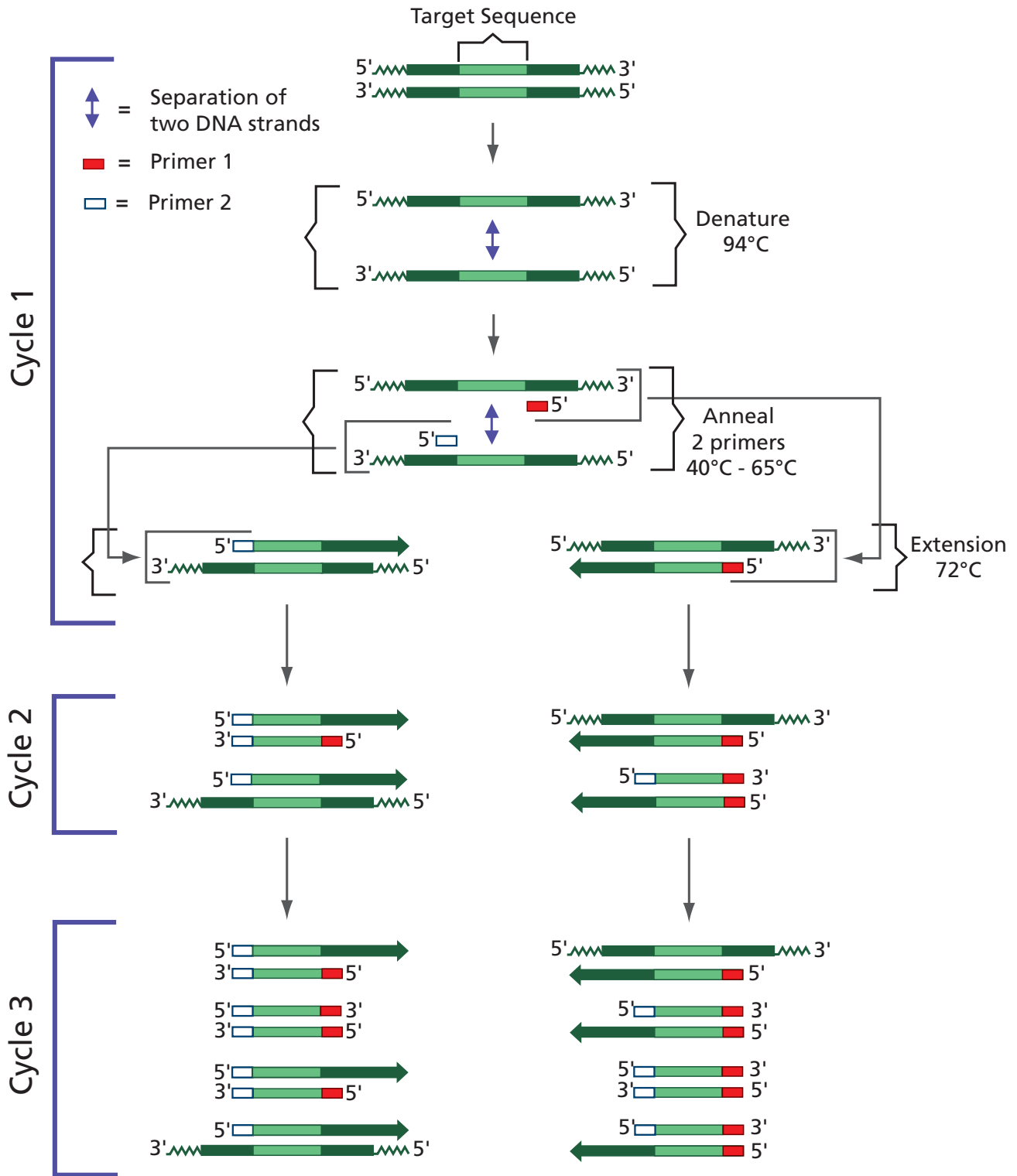

Figure 1:
Polymerase Chain Reaction

REINVENTING PCR

While PCR is relatively fast and easy compared to techniques like the Southern blot, it still takes several hours to complete the experiment. In response, researchers have devised several strategies to reduce the time necessary to amplify a specific sequence. One timesaving strategy involves designing the primers so that the annealing temperature and the extension temperature are very close. This allows researchers to combine the annealing and extension steps of the traditional PCR cycle. Another timesaving strategy involves reducing the time spent at each temperature. By modifying the PCR program, researchers could reduce the length of each cycle from 90-150 seconds to 60 seconds or less (Table 1). These changes reduce the time required for this experiment by over 50%.

Table 1:
Comparison of Traditional and Quick PCR

	Traditional PCR	Quick PCR
Denaturation (95° C)	45s	30s
Annealing (40° C - 60° C)	45s	0s
Extension (72° C)	45s	30s
TOTAL TIME (30 cycles)	~70 minutes	~30 minutes

In this exploration, we will use quick PCR to analyze genomic DNA isolated from a virus that infects *E. coli*, known as bacteriophage lambda. Historically, lambda is an important virus for molecular biology. Early studies of the lambda genome contributed to our understanding of DNA replication, transcription, and translation. The 48,500 base pair genome contains information necessary for the virus's entry into the cell, production of new virions, and lysis of the host cell (Figure 2). The primers used in this experiment have been designed to amplify a 500 base pair region of a viral capsid protein. They are engineered to have an annealing temperature of 71° C, which is close to the optimum temperature for *Taq*'s DNA polymerase activity. This allows us to combine the annealing and extension steps of PCR. As a result, the entire amplification can be performed in about thirty minutes, allowing your students to perform PCR in a single lab period.

Figure 2:
Lambda Phage Map

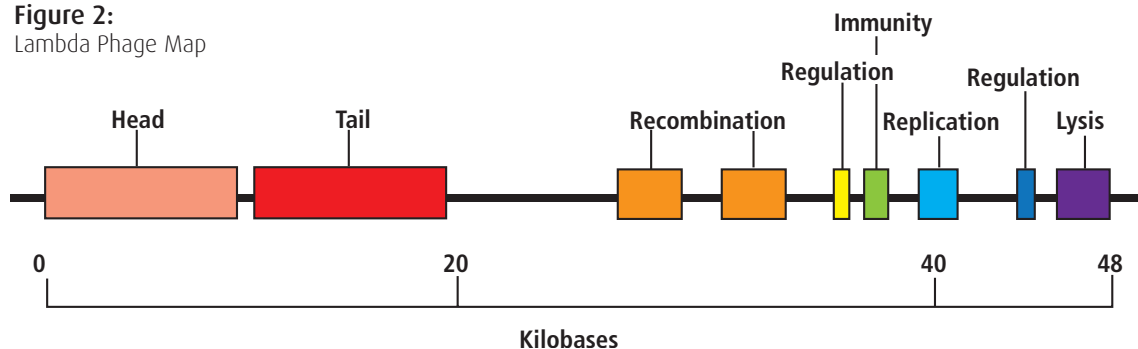

Experiment Overview

EXPERIMENT OBJECTIVE:

In this experiment, students will gain an understanding of the traditional three-step Polymerase Chain Reaction (PCR). Using PCR and Agarose Gel Electrophoresis, they will analyze a small section of Lambda DNA in a time-saving two-step process.

LABORATORY SAFETY:

Be sure to READ and UNDERSTAND the instructions completely BEFORE starting the experiment. If you are unsure of something, ASK YOUR INSTRUCTOR!

- Wear gloves and goggles while working in the laboratory.
- Exercise caution when working in the laboratory – you will be using equipment that can be dangerous if used incorrectly.
- Wear protective gloves when working with hot reagents like boiling water and melted agarose.
- DO NOT MOUTH PIPET REAGENTS - USE PIPET PUMPS.
- Always wash hands thoroughly with soap and water after working in the laboratory.

LABORATORY NOTEBOOKS:

Scientists document everything that happens during an experiment, including experimental conditions, thoughts and observations while conducting the experiment, and, of course, any data collected. Today, you'll be documenting your experiment in a laboratory notebook or on a separate worksheet.

Before starting the Experiment:

- Carefully read the introduction and the protocol. Use this information to form a hypothesis for this experiment.
- Predict the results of your experiment.

During the Experiment:

- Record your observations.

After the Experiment:

- Interpret the results – does your data support or contradict your hypothesis?
- If you repeated this experiment, what would you change? Revise your hypothesis to reflect this change.

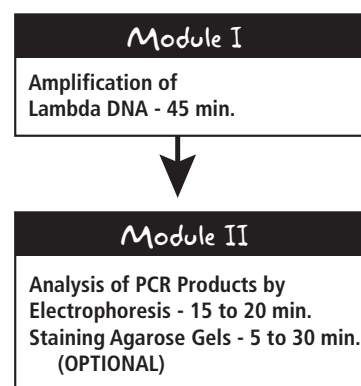

NOTE: Experimental times are approximate.

Module I: Amplification of Lambda DNA

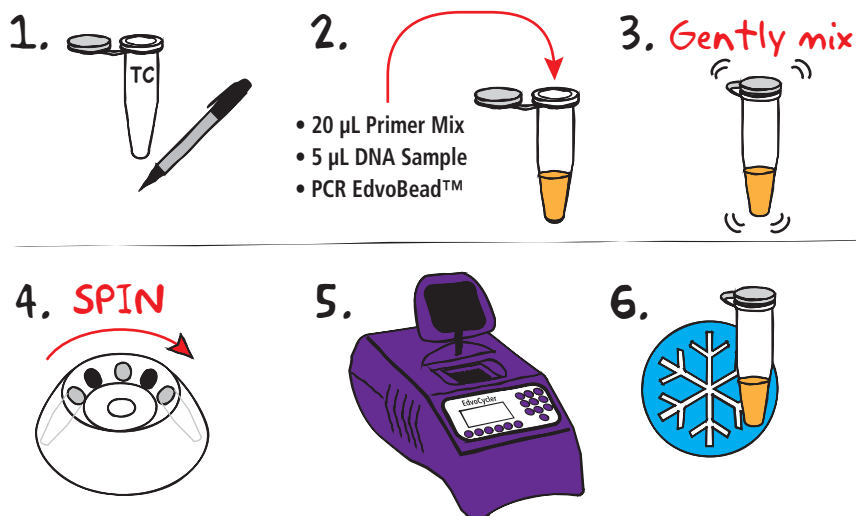

NOTES AND REMINDERS:

At least one negative control should be performed per class. To prepare the control sample, add 20 µL Primer Mix and 5 µL Lambda DNA template to a labeled PCR tube. NO PCR EdvoBead™ IS ADDED.

If your thermal cycler does not have a heated lid, it is necessary to overlay the PCR reaction with wax to prevent evaporation. See our website for more information.

- LABEL** a PCR tube with the sample and your initials
- ADD** 20 µL primer mix (yellow), 5 µL DNA sample (red) and one PCR EdvoBead™ to the appropriately labeled 0.2 mL PCR tube.
- MIX** each PCR sample. Make sure the PCR EdvoBeads™ are completely dissolved. **NOTE: Double-check that both the primer and DNA have been added by looking at the color of the mixture in the PCR tube. The mixture should be orange with the primer and DNA mixed together.**
- CENTRIFUGE** the samples for a few seconds to collect the sample at the bottom of the tubes.
- AMPLIFY** DNA using PCR.
PCR cycling conditions:
 - Initial denaturation 94° C for 3 minutes
 - 94° C for 30 seconds
 - 71° C for 30 seconds
 } 20 cycles
- After PCR, **PLACE** tubes on ice. **PROCEED** to Module II: Separation of PCR Products by Electrophoresis.



OPTIONAL STOPPING POINT:

The PCR samples may be stored at -20° C for electrophoresis at a later time.



NOTE:

PCR Cycling Conditions have changed. Please review your PCR program before performing the experiment.

Overview of Agarose Gel Electrophoresis & Staining

1

Prepare agarose gel & casting tray. If using **SYBR® Safe DNA Stain (PREFERRED METHOD)**, gel preparation begins on page 11. If using **FlashBlue™**, gel preparation procedures begin on page 14.

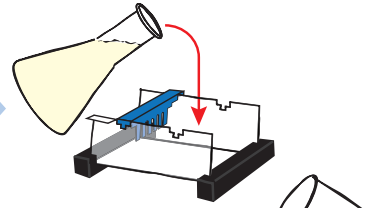

2

Remove end caps & comb. Place tray into the electrophoresis chamber. Add 1x buffer into the chamber to submerge the gel.

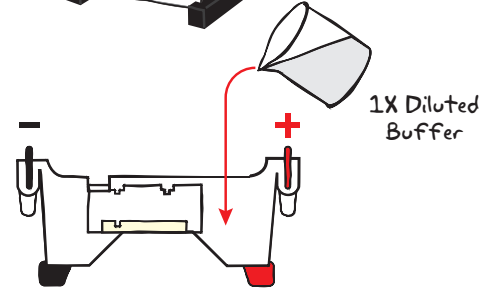

3

Using a variable micropipette, load each sample into consecutive wells.

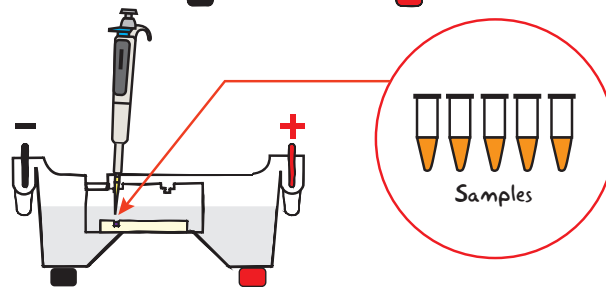

4

Attach safety cover, connect leads to power source and conduct electrophoresis.

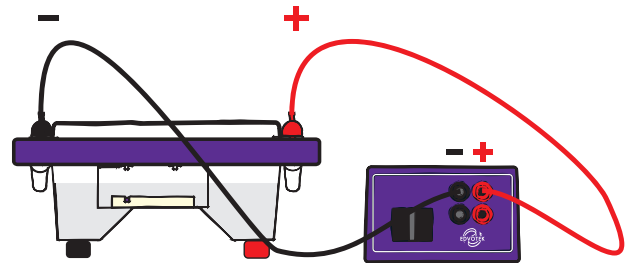

5

After electrophoresis, if **SYBR® Safe** was used, proceed directly to visualizing the gel. If using **FlashBlue™**, transfer the gel for staining.

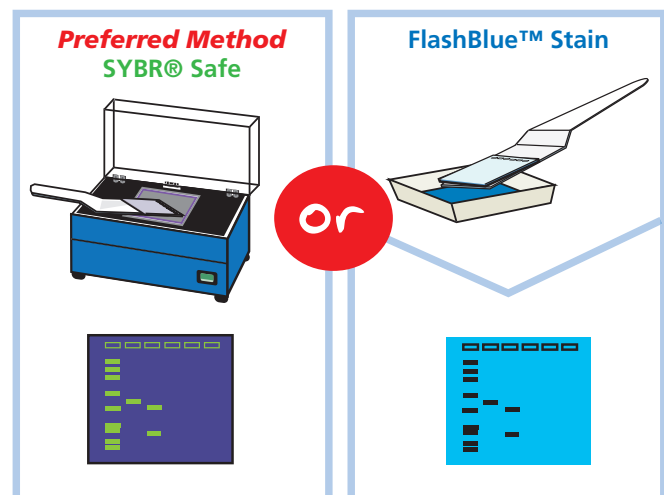

6

Visualize results on a U.V. Trans-illuminator or Blue Light Visualization system (**SYBR® Safe**) or a white light system (**FlashBlue™ Stain**).

Gel pattern will vary depending upon experiment.

Module II-A: Separation of PCR Products by Electrophoresis (SYBR® Safe DNA Stain)

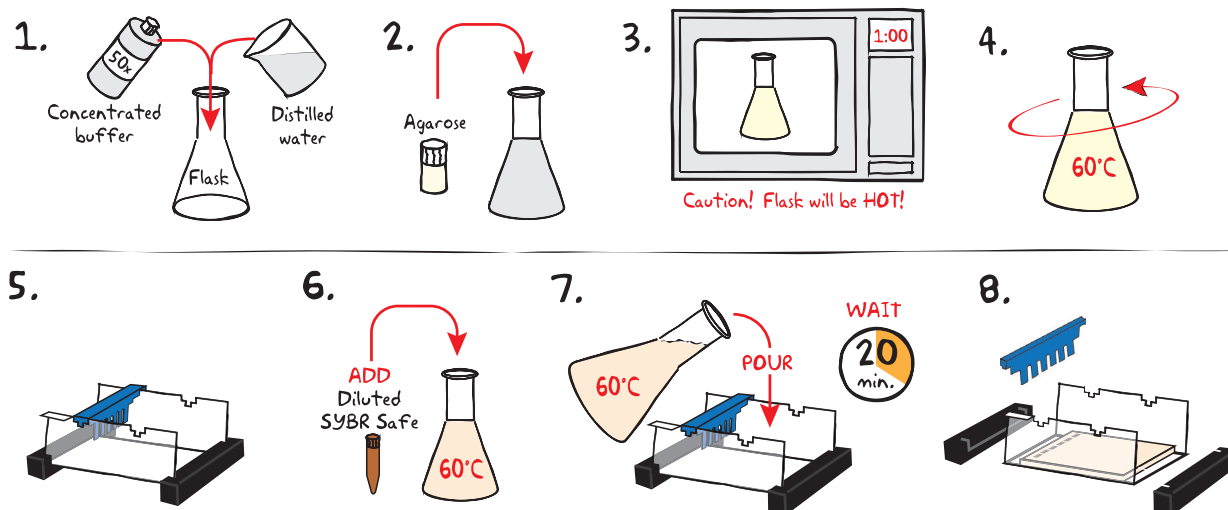
PREFERRED METHOD

PREPARING THE AGAROSE GEL WITH SYBR® SAFE STAIN

- DILUTE** concentrated (50X) buffer with distilled water to create 1X buffer (see Table A.1).
- MIX** agarose powder with 1X buffer in a 250 mL flask (see Table A.1).
- DISSOLVE** agarose powder by boiling the solution. **MICROWAVE** the solution on high for 1 minute. Carefully **REMOVE** the flask from the microwave and **MIX** by swirling the flask. Continue to **HEAT** the solution in 15-second bursts until the agarose is completely dissolved (the solution should be clear like water).
- COOL** the agarose to 60° C by carefully swirling the flask to promote even dissipation of heat.
- While the agarose is cooling, **SEAL** the ends of the gel-casting tray with the rubber end caps. **PLACE** the comb in the appropriate notch.
- Before casting the gel, **ADD** diluted SYBR® Safe stain to the cooled molten agarose and swirl to mix (see Table A.1).
- POUR** the cooled agarose solution into the prepared gel-casting tray. The gel should thoroughly solidify within 20 minutes. The gel will stiffen and become less transparent as it solidifies.
- REMOVE** the end caps and comb. Take particular care when removing the comb to prevent damage to the wells.

IMPORTANT:

7 x 7 cm gels are recommended. Place the comb in the first set of notches.

If you are unfamiliar with agarose gel prep and electrophoresis, detailed instructions and helpful resources are available at www.edvotek.com



OPTIONAL STOPPING POINT:

Gels can be stored overnight submerged in electrophoresis buffer, in the fridge, and protected from light.

Table
A.1

Individual 0.8% UltraSpec-Agarose™ Gel
with SYBR® Safe Stain

Size of Gel Casting tray	Concentrated Buffer (50x)	Distilled Water +	Amt of Agarose	= TOTAL Volume	Diluted SYBR® (Step 6)
7 x 7 cm	0.5 mL	24.5 mL	0.23g	25 mL	25 µL
7 x 14 cm	1.0 mL	49.0 mL	0.46 g	50 mL	50 µL

Module II-A: Separation of PCR Products by Electrophoresis (SYBR® Safe DNA Stain), continued

PREFERRED METHOD

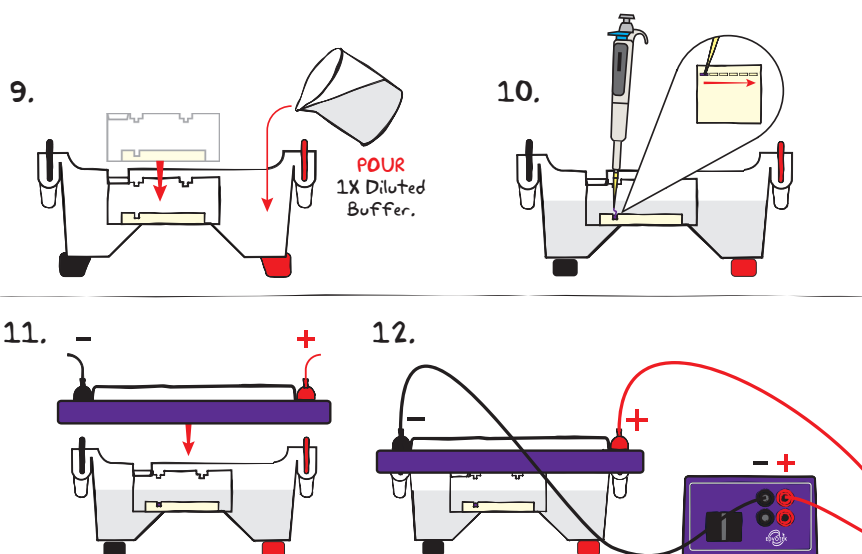

Reminder:

Before loading the samples, make sure the gel is properly oriented in the apparatus chamber.



Wear gloves and safety goggles

RUNNING THE GEL

9. **PLACE** the gel (on the tray) into the electrophoresis chamber. **COVER** the gel with 1X electrophoresis buffer (See Table B.1 for recommended volumes). The gel should be completely submerged.
10. Using Table 2 as a guide, **LOAD** the entire sample (25 μ L) into the wells in consecutive order.
11. **PLACE** safety cover. **CHECK** that the gel is properly oriented. Remember, the DNA samples will migrate toward the positive (red) electrode.
12. **CONNECT** leads to the power source and **PERFORM** electrophoresis (See Table C for time and voltage guidelines).
13. After electrophoresis is complete, **REMOVE** the gel and casting tray from the electrophoresis chamber.



OPTIONAL STOPPING POINT:

Gels can be stored for several days. Place gel in a watertight plastic bag with 2 mL of electrophoresis buffer and store in the refrigerator.

Table 2

Lane	Recommended	Sample Name
1	EdvoQuick™ DNA ladder	
2	Negative Control*	
3	Student Group #1	
4	Student Group #2	
5	Student Group #3	
6	Student Group #4	

* Optional, or additional student group sample.

Table B.1 1x Electrophoresis Buffer (Chamber Buffer)

EDVOTEK Model #	Total Volume Required	Dilution	
		50x Conc. Buffer	+ Distilled Water
M6+ & M12 (new)	300 mL	6 mL	294 mL
M12 (classic)	400 mL	8 mL	392 mL
M36	1000 mL	20 mL	980 mL

Table C Time and Voltage Guidelines (0.8% - 7 x 7 cm Agarose Gel)

Volts	Recommended Time	
	Minimum	Maximum
150	10 min.	20 min.
125	20 min.	35 min.
70	35 min.	1 hour

Module II-A: Separation of PCR Products by Electrophoresis (SYBR® Safe DNA Stain), continued

PREFERRED METHOD



14.

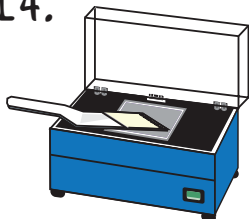

15.

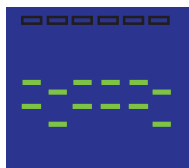

16.

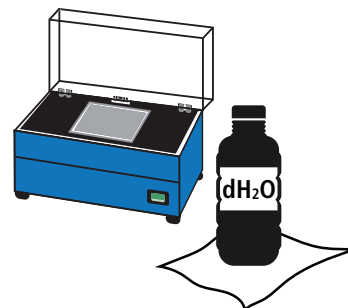

VISUALIZING THE SYBR® GEL

14. **SLIDE** the gel off the casting tray onto the viewing surface of the transilluminator and turn the unit on. **ADJUST** the brightness to the desired level to maximize band visualization. DNA should appear as bright green bands on a dark background.
15. **PHOTOGRAPH** the results.
16. **REMOVE** and **DISPOSE** of the gel and **CLEAN** the transilluminator surfaces with distilled water.



Be sure to wear UV goggles if using a UV transilluminator.

Module II-B: Separation of PCR Products by Electrophoresis (Improved FlashBlue™ Staining)

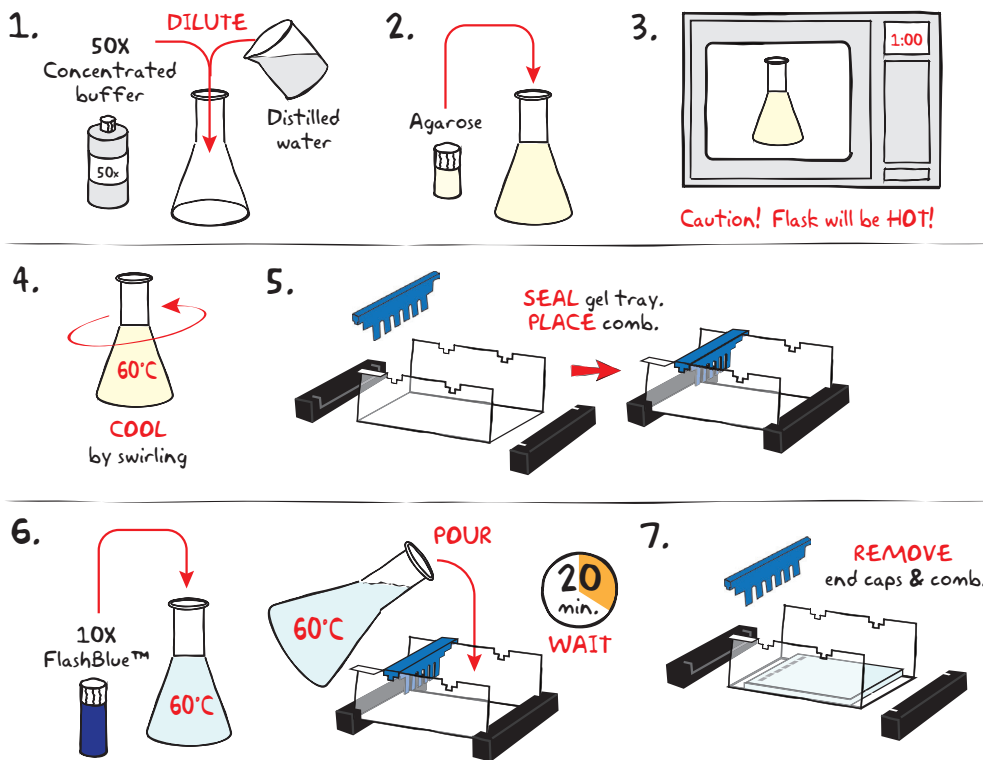

IMPORTANT:

7 x 7 cm gels are recommended. Place well-former template (comb) in the first set of notches.

If you are unfamiliar with agarose gel prep and electrophoresis, detailed instructions and helpful resources are available at www.edvotek.com



Wear gloves and safety goggles

PREPARING THE AGAROSE GEL WITH FLASHBLUE™

- DILUTE** concentrated (50X) buffer with distilled water to create 1X buffer (see Table A.2).
- MIX** agarose powder with 1X buffer in a 250 mL flask (see Table A.2).
- DISSOLVE** agarose powder by boiling the solution. **MICROWAVE** the solution on high for 1 minute. Carefully **REMOVE** the flask from the microwave and **MIX** by swirling the flask. Continue to **HEAT** the solution in 15-second bursts until the agarose is completely dissolved (the solution should be clear like water).
- COOL** agarose to 60° C with careful swirling to promote even dissipation of heat.
- While agarose is cooling, **SEAL** the ends of the gel casting tray with the rubber end caps. **PLACE** the comb in the appropriate notch.
- ADD** 10X FlashBlue™ Solution to the cooled agarose (see Table A.3 for correct amount). **POUR** the cooled agarose solution into the prepared gel casting tray. The gel should thoroughly solidify within 20 minutes. The gel will stiffen and become less transparent as it solidifies.
- Carefully **REMOVE** end caps and comb. Take particular care when removing the comb to prevent damage to the wells.

Table A.2 Individual 0.8% UltraSpec-Agarose™ Gel

Size of Gel Casting tray	Concentrated Buffer (50x)	Distilled Water	Amt of Agarose	= TOTAL Volume
7 x 7 cm	0.6 mL	29.4 mL	0.23g	30 mL
7 x 14 cm	1.2 mL	58.8 mL	0.46 g	60 mL

Table A.3 FlashBlue™ Enhanced Gel

Size of Gel	Amt of FlashBlue™
7 x 7 cm	10 µL
7 x 14 cm	20 µL

Module II-B: Separation of PCR Products by Electrophoresis (Improved FlashBlue™ Staining), continued

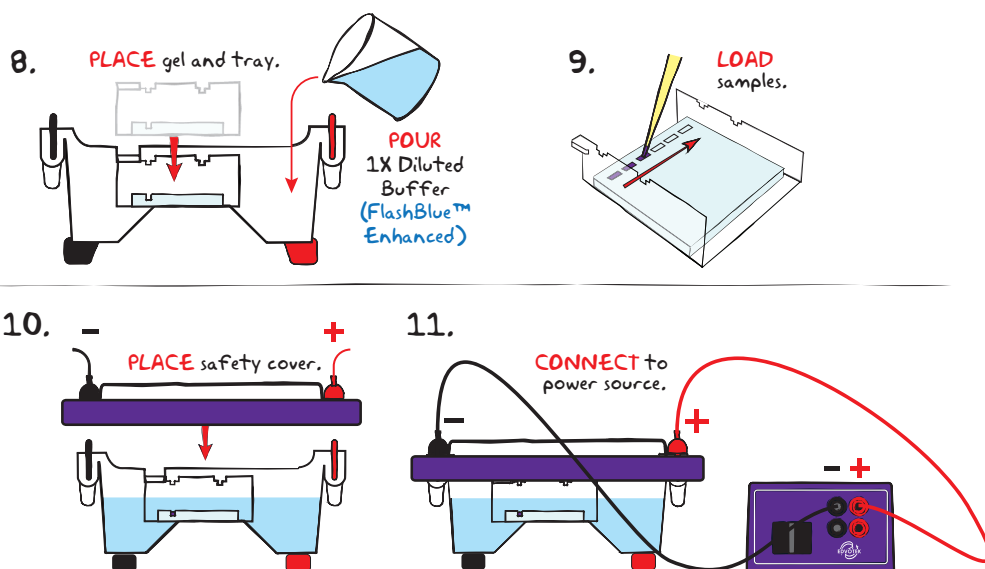

Reminder:

Before loading the samples, make sure the gel is properly oriented in the apparatus chamber.



Wear gloves and safety goggles

RUNNING THE GEL

- PLACE** gel (on the casting tray) into electrophoresis chamber. **POUR** the FlashBlue™ Enhanced 1X Diluted Chamber Buffer into the electrophoresis chamber (See Table B.2 for recommended volumes). Completely **SUBMERGE** the gel.
- LOAD** the entire sample volumes (25 μ L) into the wells in consecutive order as indicated by Table 2.
- PLACE** safety cover. **CHECK** that the gel is properly oriented. Remember, the samples will migrate toward the positive (red) electrode.
- CONNECT** leads to the power source and **PERFORM** electrophoresis (See Table C for time and voltage guidelines). For best results, the orange tracking dye should migrate at least 4 cm from the wells.
- After electrophoresis is complete, **REMOVE** the gel and casting tray from the electrophoresis chamber and proceed to **STAINING** the agarose gel with FlashBlue™ Stain (page 16).

EDVOTEK Model #	Total Volume Required	DILUTION		
		50x Conc. Buffer	+ Distilled Water	+ 10x FlashBlue Solution
M6+ & M12 (new)	300 mL	6 mL	294 mL	100 μ L
M12 (classic)	400 mL	8 mL	392 mL	130 μ L
M36	1000 mL	20 mL	980 mL	330 μ L

Table 2

Lane	Recommended	Sample Name
1	EdvoQuick™ DNA ladder	
2	Negative Control*	
3	Student Group #1	
4	Student Group #2	
5	Student Group #3	
6	Student Group #4	

* Optional, or additional student group sample.

Volts	Recommended Time	
	Minimum	Maximum
150	10 min.	20 min.
125	20 min.	35 min.
70	35 min.	1 hour

1.800.EDVOTEK • Fax 202.370.1501 • info@edvotek.com • www.edvotek.com

Module II-B: Separation of PCR Products by Electrophoresis (Improved FlashBlue™ Staining), continued

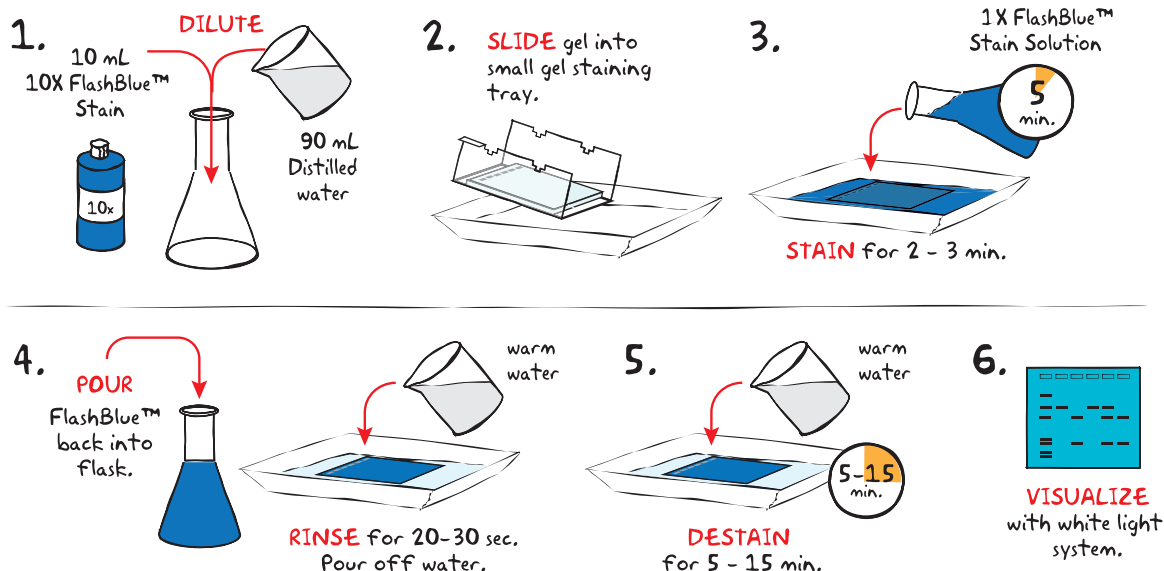

STAINING AND VISUALIZING WITH FLASHBLUE™ STAIN

- DILUTE** 10 mL of 10X concentrated FlashBlue™ with 90 mL of distilled water in a flask. **MIX** well.
- REMOVE** the agarose gel and casting tray from the electrophoresis chamber. **SLIDE** the gel off of the casting tray into a small, clean gel staining tray.
- COVER** the gel with the 1X FlashBlue™ stain solution. **STAIN** the gel for 5 minutes. For best results, use an orbital shaker to gently agitate the gel while staining. **STAINING THE GEL FOR LONGER THAN 3 MINUTES WILL REQUIRE EXTRA DESTAINING TIME.**
- POUR** the 1X FlashBlue™ back into the flask (the stain can be reused). **COVER** the gel with warm water (40-45° C). Gently **RINSE** the gel for 20-30 seconds. **POUR** off the water.
- COVER** the gel with 100 mL clean, warm water (40-45° C). **DESTAIN** for 5-15 minutes with gentle shaking (longer periods will yield better results). DNA bands will start to appear after 5 minutes of destaining. Frequent changes of the water will accelerate destaining.
- Carefully **REMOVE** the gel from the destaining liquid. **VISUALIZE** results using a white light visualization system. DNA will appear as dark blue bands on a light blue background.



ALTERNATIVE FLASHBLUE™ STAINING PROTOCOL:

- DILUTE** 1 mL of 10X FlashBlue™ stain with 499 mL distilled water.
- COVER** the gel with diluted FlashBlue™ stain.
- SOAK** the gel in the staining liquid for at least three hours. For best results, stain gels overnight.
- Carefully **REMOVE** the gel from the staining liquid. **VISUALIZE** results using a white light visualization system. DNA will appear as dark blue bands on a light blue background.

Study Questions

1. Why is a thermostable DNA polymerase required for PCR-based DNA amplification?
2. Why are two different primers required for the PCR reaction?
3. How do traditional PCR and quick PCR differ? How do these changes affect the time spent performing PCR?

Instructor's Guide

OVERVIEW OF INSTRUCTOR'S PRELAB PREPARATION:

This section outlines the recommended prelab preparations and approximate time requirement to complete each prelab activity.

This kit provides two staining options for analyzing the agarose gels: SYBR® Safe Stain and Enhanced FlashBlue™ Stain. The instructor **MUST DECIDE** which stain will be used before starting gel preparation in Module II. See page 20 for additional information on both staining options.

Preparation For:	What to do:	When:	Time Required:
Module I: Amplification of Lambda DNA	Prepare and aliquot various reagents (Primer, DNA template, ladder, etc.)	Up to 2 hours before performing the experiment.	30 min.
	Program Thermal Cycler.	Any time before performing the experiment.	15 min.
Module II: Separation of PCR Products by Electrophoresis	Prepare diluted electrophoresis buffer	Up to one week before performing the experiment.	45 min.
	Prepare molten agarose and pour batch gels (OPTIONAL)		
Module II-A: SYBR® Safe Stain	Prepare SYBR® Safe Stain.	Up to 24 hours before performing the experiment.	10 min.
Module II-B: FlashBlue™ Staining	Prepare staining components	The class period or overnight after the class period.	10 min.

■ Red = Prepare immediately before module.
 ■ Yellow = Prepare shortly before module.
 ■ Green = Flexible / prepare up to a week before the module.

NOTE:

The PCR cycling conditions may have changed. Before running the experiment, confirm that the program matches the settings below.

- Initial denaturation 94° C for 3 minutes
 - 94° C for 30 seconds
 - 71° C for 30 seconds
- } 20 cycles

Pre-Lab Preparations - Module I

AMPLIFICATION OF LAMBDA DNA

This kit features the NEW EDVOTEK® LyphoTemplate™ and LyphoPrimer™. The reagents are color coded so that a correctly assembled PCR reaction should appear orange in color. This innovation will help ensure experimental success.

Preparation of the Primer Mix

1. Thaw the TE buffer (D). Mix well before using.
2. Before preparing the primer mix, make sure the solid material is at the bottom of the LyphoPrimer™ Tube (A). If not, centrifuge the tube at full speed for 20 seconds or tap the tube on the lab bench.
3. Dilute the LyphoPrimer™ by adding 1 mL of TE Buffer to the tube. Cap and mix well and place on ice. The solution should be clear and light yellow in color, and no solid pieces should remain.
4. Dispense 25 µL of the diluted primer per tube. Label these 10 tubes "Primer Mix". Distribute one tube per student group.

Preparation of the DNA Template

1. Thaw the TE buffer (D). Mix well before using.
2. Before preparing the DNA template, make sure the solid material is at the bottom of the LyphoTemplate™ Tube (C). If not, centrifuge the tube at full speed for 20 seconds or tap the tube on the lab bench.
3. Dilute the LyphoTemplate™ Lambda DNA by adding 75 µL of TE Buffer to the tube. Cap and mix well and place on ice. The solution should be clear and red in color, and no solid pieces should remain.
4. Dispense 6 µL of the diluted DNA template per tube. Label these 10 tubes "Lambda DNA". Distribute one tube per student group.
5. This kit provides enough template DNA for two negative control reactions. Distribute one additional tube containing 6 µL diluted Lambda DNA to the groups preparing the control samples.

Additional Materials

- Each student group receives one 0.2 mL PCR tube and one PCR EdvoBead™.

PCR Amplification

The Thermal cycler should be programmed as outlined in Module I in the Student's Experimental Procedure.

- Accurate temperatures and cycle times are critical. A pre-run for one cycle (takes approximately 3 to 5 min.) is recommended to check that the thermal cycler is properly programmed.
- For thermal cyclers that do not have a heated lid, it is necessary to place a layer of wax or mineral oil above the PCR reactions in the microcentrifuge tubes to prevent evaporation. Visit www.edvotek.com for more information.

FOR MODULE I

Each Group should receive:

- One PCR tube and PCR EdvoBead™
- 25 µL Diluted Primer Mix
- 6 µL Diluted Lambda DNA Template
- Additional 6 µL Diluted Lambda DNA Template for designated group performing the Optional Control Reaction

NOTE:

Sample volumes are very small. It is important to quick spin the tube contents in a microcentrifuge to obtain sufficient volume for pipetting. Spin samples for 10-20 seconds at maximum speed.

LyphoTemplate™

LyphoPrimer™



NOTE:

PCR Cycling Conditions have changed. Please review your PCR program before performing the experiment.

Pre-Lab Preparations - Module II

SEPARATION OF PCR PRODUCTS BY ELECTROPHORESIS

NOTE: The instructor **MUST DECIDE** whether to use SYBR® Safe or FlashBlue™ to visualize the gel **BEFORE** starting the gel preparation in Module II.

Prepare SYBR® Safe Stain (if using in Module II):

1. Following the instructions in Appendix C, prepare 1x Electrophoresis Buffer by combining 10 µL of 50X Concentrated Buffer with 490 µL of distilled water.
2. Add 250 µL of the 1X buffer from step 1 to the tube of SYBR® Safe and mix by tapping the tube several times. The SYBR® Safe Stain is now ready to be used during agarose gel preparation.

Individual Gel Preparation:

This experiment requires a total of three 0.8% agarose gels shared by the entire class. 7 x 7 cm gels are recommended. Each student group can be responsible for casting their own individual gel prior to conducting the experiment. See Module II in the Student's Experimental Procedure. Students will need 50X electrophoresis buffer, distilled water, agarose powder, and either diluted SYBR® Safe Stain or 10X FlashBlue™ solution.

Batch Gel Preparation:

To save time, a larger quantity of agarose solution can be prepared for sharing by the class. Electrophoresis buffer can also be prepared in bulk. See Appendix C.

Preparing Gels in Advance:

Gels may be prepared ahead and stored for later use. Solidified gels can be stored under buffer in the refrigerator (4° C) for up to two days.

If using the Improved FlashBlue™ staining protocol, the buffer should contain FlashBlue™. See Table B.2 on page 15 for preparation guidelines.

Do not freeze gels at -20° C as freezing will destroy the gels.

Gels that have been removed from their trays for storage should be "anchored" back to the tray with a few drops of molten agarose before being placed into the tray. This will prevent the gels from sliding around in the trays and the chambers.

Additional Materials:

- Dispense 35 µL of the EdvoQuick™ DNA ladder (B) into 3 microcentrifuge tubes labeled "Ladder". Distribute one tube of EdvoQuick™ DNA ladder per gel.

NOTE:

Accurate pipetting is critical for maximizing successful experiment results. This experiment is designed for students who have had previous experience with micropipetting techniques and agarose gel electrophoresis.

If students are unfamiliar with using micropipettes, we recommend performing Cat. #S-44, Micropipetting Basics or Cat. #S-43, DNA DuraGel™ prior to conducting this advanced level experiment.

FOR MODULE II Each Group should receive:

- 50X concentrated buffer
- Distilled Water
- UltraSpec-Agarose™ Powder
- EdvoQuick DNA ladder (35 µL)
- Diluted SYBR® Safe or 10X FlashBlue™ Stain

NOTE:

QuickGuide instructions and guidelines for casting various agarose gels can be found on our website.

www.edvotek.com/quick-guides

Pre-Lab Preparations - Module II

STAINING & VISUALIZING AGAROSE GELS

Module II-A: SYBR® Safe stain (*PREFERRED METHOD*)

SYBR® Safe is a fluorescent DNA stain that binds specifically to DNA. Students can obtain safe and rapid results from their electrophoresis experiment by adding a diluted solution of SYBR® Safe to molten agarose before casting a gel. When excited with UV or blue light, any SYBR® Safe that is bound to DNA fluoresces with a bright green color. Fluorescent DNA stains like SYBR® Safe are perfect for technically challenging experiments like PCR because they are extremely sensitive, making it easy to quantify small amounts of DNA.

Use a mid-range ultraviolet transilluminator (Cat #558) or TruBlu™ Blue Light Transilluminator (Cat #557) to visualize gels stained with SYBR® Safe. Gels are ready to visualize immediately after electrophoresis is completed.

Module II-B: FlashBlue™ Stain

FlashBlue™ stain is optimized to shorten the time required for both staining and destaining steps. The gels are prestained with FlashBlue™ by adding the concentrate to the gel and running buffer. Agarose gels can be stained with diluted FlashBlue™ for 5 minutes and destained for only 20 minutes. For the best results, leave the gel in liquid overnight. This will allow the stained gel to “equilibrate” in the destaining solution, resulting in dark blue DNA bands contrasting against a uniformly light blue background. A white light box (Cat. #552) is recommended for visualizing gels stained with FlashBlue™.

FOR MODULE II-B
Each Group should receive:

- 10 mL 10X concentrated FlashBlue OR 100 mL 1X diluted FlashBlue
- Small plastic tray or weight boat
- Distilled or deionized water

- Stained gels may be stored in destaining liquid for several weeks with refrigeration, although the bands may fade with time. If this happens, re-stain the gel.
- Destained gels can be discarded in solid waste disposal. Destaining solutions can be disposed of down the drain.

PHOTODOCUMENTATION OF DNA (OPTIONAL)

Once gels are stained, you may wish to photograph your results. There are many different photodocumentation systems available, including digital systems that are interfaced directly with computers. Specific instructions will vary depending upon the type of photodocumentation system you are using.

Experiment Results and Analysis

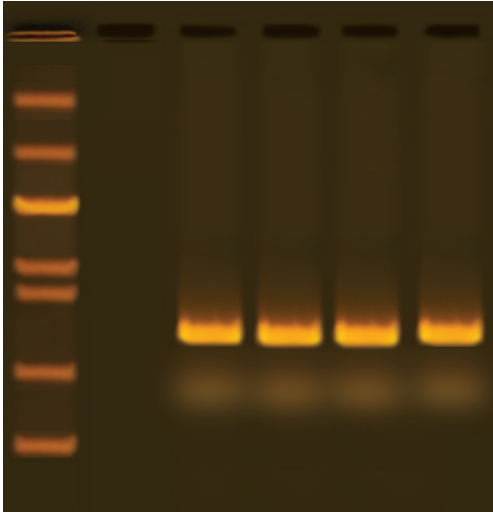

The result photos represent the PCR products stained with SYBR® Safe (top) and FlashBlue™ (bottom). This PCR experiment will amplify a 500 base pair region of a viral capsid protein coded for by the lambda genome. The control experiment will not produce a PCR product because it is missing the PCR EdvoBead™.

- Lane 1 EdvoQuick™ DNA Ladder
- Lane 2 Negative Control (no PCR EdvoBead™)
- Lane 3 Student Group #1 PCR Reaction (20 cycles)
- Lane 4 Student Group #2 PCR Reaction (20 cycles)
- Lane 5 Student Group #3 PCR Reaction (20 cycles)
- Lane 6 Student Group #4 PCR Reaction (20 cycles)

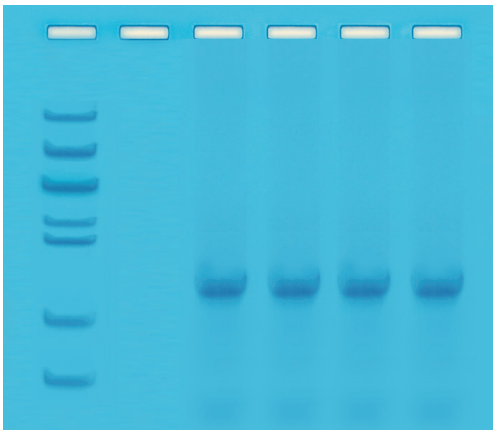

NOTES:

Depending on the PCR conditions used, a diffuse, small-molecular weight band, known as a "primer dimer", may be present below the 200 bp marker. This is a PCR artifact and can be ignored. Other minor bands may also appear due to nonspecific primer binding and the subsequent amplification of these sequences.

The red and yellow dyes from the LyphoTemplate™ and LyphoPrimer™ will migrate at different positions on the electrophoresis gel. Be sure to use the **blue band from the ladder**, as opposed to the red and yellow bands from the samples, to determine how far the DNA samples have run.

Includes EDVOTEK's All-NEW EdvoQuick™ DNA Ladder

- Better separation
- Easier band measurements
- No unused bands

EdvoQuick™ DNA ladder sizes:
2640, 1400, 1100, 700, 600, 400, 200

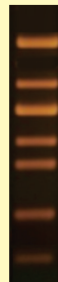

**Please refer to the kit
insert for the Answers to
Study Questions**

Appendices

- A EDVOTEK® Troubleshooting Guide
- B Performing the PCR Experiment Using Two Waterbaths
- C Bulk Preparation of Electrophoresis Buffer and Agarose Gels

Safety Data Sheets can be found on our website: www.edvotek.com/Safety-Data-Sheets

EDVO-TECH Service

1.800.EDVOTEK

Mon. - Fri. 8am-5:30pm EST



Please Have the Following Info:

- Product Number & Description
- Lot Number on Box
- Order/Purchase Order #
- Approx. Purchase Date

Fax: 202.370.1501 • info@edvotek.com • www.edvotek.com

www.edvotek.com

- Online Catalog
- Order Products
- Experiment Protocols
- Tech Support
- Resources!



1.800.EDVOTEK • Fax 202.370.1501 • info@edvotek.com • www.edvotek.com

Duplication of any part of this document is permitted for non-profit educational purposes only. Copyright © 1989-2019 EDVOTEK, Inc., all rights reserved. 372.190123

Appendix A

EDVOTEK® Troubleshooting Guides

PCR AND ELECTROPHORESIS

PROBLEM:	CAUSE:	ANSWER:
There is very little liquid left in tube after PCR.	Sample has evaporated.	<p>Make sure the heated lid reaches the appropriate temperature.</p> <p>If your thermal cycler does not have a heated lid, overlay the PCR reaction with wax (visit www.edvotek.com for details).</p> <p>Make sure students close the lid of the PCR tube properly.</p>
	Pipetting error.	Make sure students pipet 20 μ L Primer Mix, and 5 μ L DNA Template into the appropriate tube. When properly prepared, the PCR sample will appear orange in color.
The ladder and student PCR products are not visible on the gel.	The gel was not prepared properly.	<p>Ensure that the electrophoresis buffer was correctly diluted.</p> <p>Gels of higher concentration (> 0.8%) require special attention when melting the agarose. Make sure that the solution is completely clear of "clumps" and glassy granules before pouring gels.</p> <p>The proper buffer was not used for gel preparation. Make sure to use 1x Electrophoresis Buffer.</p>
	The gel was not stained properly.	Ensure that stain was added to the gel. Repeat staining.
	Malfunctioning electrophoresis unit or power source.	Contact the manufacturer of the electrophoresis unit or power source.
After staining the gel with FlashBlue™, the DNA bands are faint.	The gel was not stained for a sufficient period of time.	Repeat staining protocol.
After staining the gel with FlashBlue™, the gel background is very dark.	The gel needs to be destained longer.	Submerge the gel in distilled or deionized water. Allow the gel to soak for 5 minutes.
After staining, the ladder is visible on the gel but some student samples are not present.	PCR EdvoBead™ was added to the wrong tube.	Be sure to add the PCR EdvoBead™ to the 0.2 mL PCR tube.
	Wrong volumes of DNA and primer added to PCR reaction.	Practice using micropipettes. When properly prepared, the PCR sample will appear orange in color.
Low molecular weight band in PCR samples.	Primer dimer.	Low concentration of DNA in PCR sample as a result of pipetting error. Be sure student pipets 5 μ L DNA template into the appropriate tube.
DNA bands were not resolved.	To ensure adequate separation, make sure the blue tracking dye migrates at least 3.5 cm on 7x7 cm gels and 6 cm on 7x14 cm gels.	Be sure to run the gel the appropriate distance before staining and visualizing the DNA.
DNA bands fade when gels are kept at 4°C.	DNA stained with FlashBlue™ may fade with time.	Re-stain the gel with FlashBlue™.

Appendix B

Performing the PCR Experiment Using Two Waterbaths

This experiment can be modified to use two waterbaths in place of a thermal cycler. In this method, the PCR samples are cycled between two waterbaths, each maintained at a different temperature, for a specified period. The sequential placement of the reaction sample between the two waterbaths constitutes one PCR cycle. Please note that results obtained when using two waterbaths are often variable. *A thermal cycler assures a significantly higher rate of success.*

We recommend EDVOTEK's Digital PCR Waterbath (Cat. #544) if you do not have access to a thermal cycler.

Set up the samples as outlined in Module I steps 1-4. Before cycling the samples, be sure to:

- Allow at least 15 minutes for the waterbaths to reach the temperatures specified in Module I (94° C and 71° C).
- Cover the waterbaths when not in use to maintain the proper temperature and to prevent water evaporation.
- The volume of the PCR sample is small and can evaporate easily. To prevent this, transfer one wax bead to each PCR sample. The melted wax bead forms a barrier over the PCR sample to prevent its evaporation during heating.
- Make sure that the sample remains undisturbed at the bottom of the tube. If necessary, centrifuge or shake the tube to get the sample to the bottom of the tube.
- Place the PCR samples in a waterbath float before placing them in the waterbath.

Continue with step 5 (thermal cycling), following the protocol below:

- Initial denaturation at 94° C for 3 minutes
 - 94° C for 30 seconds
 - 71° C for 30 seconds
- } 20 cycles

Handle the samples carefully when shifting between waterbaths. Use forceps to carefully raise/lower the float into the waterbaths.

Remove samples at specified time points. Take care to avoid the liquid wax layer when removing the sample. We recommend placing the tube on ice for a few seconds to solidify the wax. Use a clean pipette tip to gently break through the wax layer, making enough room to fit a clean pipette tip. Using a fresh, clean pipette tip, remove the PCR product and transfer to the appropriate tube.

PLACE tubes on ice. **PROCEED** to Module II: Separation of PCR Products by Electrophoresis.

Appendix C

Bulk Preparation of Electrophoresis Buffer and Agarose Gels

To save time, the electrophoresis buffer and agarose gel solution can be prepared in larger quantities for sharing by the class. Unused diluted buffer can be used at a later time and solidified agarose gel solution can be remelted.

BULK ELECTROPHORESIS BUFFER

Quantity (bulk) preparation for 3 liters of 1x electrophoresis buffer is outlined in Table D.

NOTE: If staining gels with FlashBlue, add 1 mL 10X FlashBlue concentrate to the diluted buffer and mix thoroughly.

Table D Bulk Preparation of Electrophoresis Buffer			
50x Conc. Buffer	+	Distilled Water	Total Volume Required
60 mL		2,940 mL	3000 mL (3 L)

BATCH AGAROSE GELS (0.8%)

Bulk preparation of 0.8% agarose gel is outlined in Table E.

Table E Batch Prep of 0.8% UltraSpec-Agarose™				
Amt of Agarose	+ Concentrated Buffer (50X)	+ Distilled Water	= TOTAL Volume	Cool to 60° C, ADD either: Diluted Sybr Safe OR FlashBlue Stain
2.4 g	6.0 mL	294 mL	300 mL	Entire Tube OR 130 µL

- Use a 500 mL flask to prepare the diluted gel buffer
- Pour the appropriate amount of UltraSpec-Agarose™ into the prepared buffer. Swirl to disperse clumps.
- With a marking pen, indicate the level of solution volume on the outside of the flask.
- Heat the agarose solution as outlined previously for individual gel preparation. The heating time will require adjustment due to the larger total volume of gel buffer solution.
- Cool the agarose solution to 60° C with swirling to promote even dissipation of heat. If evaporation has occurred, add distilled water to bring the solution up to the original volume as marked on the flask in step 3.
- If staining gels with SYBR® Safe stain, add the entire volume of diluted SYBR® Safe (from page 20) to the cooled agarose and mix thoroughly.
 - If staining gels with FlashBlue™, add 130 µL of 10X FlashBlue™ concentrate to the cooled agarose and mix thoroughly.
- Dispense the required volume of cooled agarose solution for casting each gel. Measure 30 mL for a 7 x 7 cm tray, 50 mL for a 7 x 10 cm tray, and 60 mL for a 7 x 14 cm tray. **For this experiment, 7 x 7 cm gels are recommended.**
- Allow the gel to completely solidify. It will become firm and cool to the touch after approximately 20 minutes. Gels can be used immediately or stored in a small amount of buffer in the refrigerator for several days.

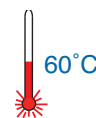

NOTE:

The UltraSpec-Agarose™ kit component is usually labeled with the amount it contains. Please read the label carefully. If the amount of agarose is not specified or if the bottle's plastic seal has been broken, weigh the agarose to ensure you are using the correct amount.

NOTE:

QuickGuide instructions and guidelines for casting various agarose gels can be found on our website.

www.edvotek.com/quick-guides