

# STRUCTURES

## Bending Stress



**MATRIX**

CP1877

[www.matrixtsl.com](http://www.matrixtsl.com)

Copyright © 2021 Matrix Technology Solutions Limited

# Contents

# Structures

## Bending stress

### Bending Stress

	Introduction	3
Worksheet 1 -	The quarter bridge	7
Worksheet 2 -	The half bridge	9
Worksheet 3 -	The full bridge	11
Worksheet 4 -	Predicting the outcome	13
	Student Handout	17
	Notes for the instructor	25

# Introduction:

# Structures Bending stress

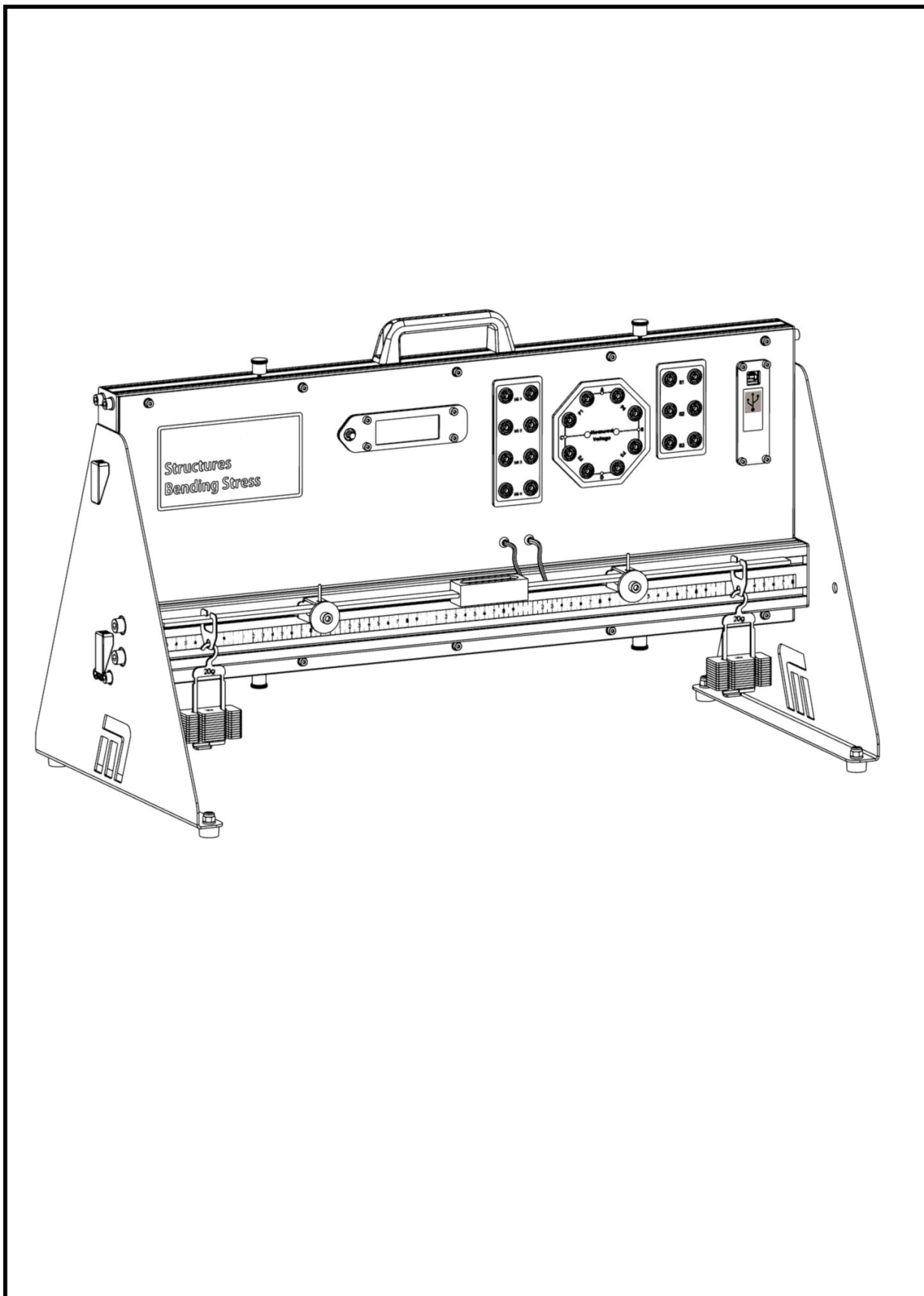

## Introduction:

# Structures

## Bending stress

### Background:

It starts with the Wheatstone bridge circuit. Invented around 1840, this circuit, named after the English physicist Charles Wheatstone, allowed measurement of an unknown electrical resistance.

It consists of four resistors connected as two voltage dividers. One of these, say  $R_1$  is the unknown resistor. Two versions of the circuit diagram are shown below:

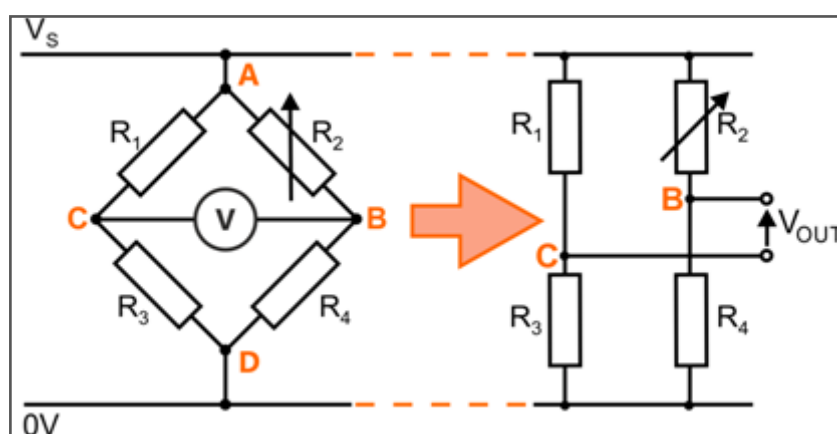

The variable resistor,  $R_2$ , is adjusted until the bridge is 'balanced' i.e the output voltage  $V_{OUT}$  is zero.

In this condition:

the voltage at **C** = the voltage at **B**

In other words,

$$\frac{V_S \times R_3}{R_1 + R_3} = \frac{V_S \times R_4}{R_2 + R_4}$$

or

$$\frac{R_3}{R_1 + R_3} = \frac{R_4}{R_2 + R_4}$$

leading to the formula:

$$\frac{R_1}{R_3} = \frac{R_2}{R_4}$$

from which the value of the unknown resistor can be obtained.

## Introduction:

# Structures

## Bending stress

### Background .....

The circuit can be modified into a strain gauge bridge circuit.

A strain gauge is a sensor whose resistance varies when it is stretched or compressed, i.e. undergoes strain. It is widely used in engineering to measure forces and weights, in load cells, for example.

One form of strain gauge is shown in the diagram opposite.

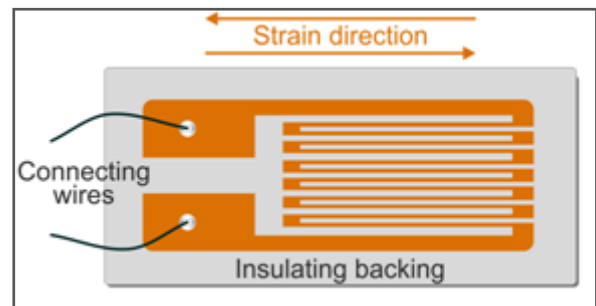

Since the resistance of a conductor depends on its length and cross-section, the resistance of a strain gauge changes when it is deformed. However, the change may be only a few per cent of its nominal resistance and so a bridge circuit is needed to provide the precision to monitor it.

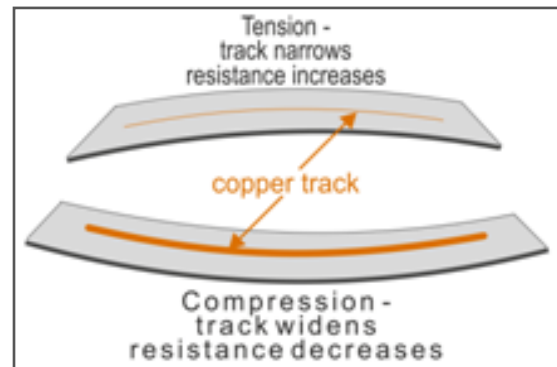

The strain gauge replaces one of the resistors in the bridge circuit. The output voltage, displayed on the LCD screen, is a measure of the strain it experiences.

Typically,  $R_4$  is chosen to have a value equal to the strain gauge resistance with no force applied. The other two resistors, ( $R_1$  and  $R_3$ ) are equal. Hence, the bridge will be balanced when the force applied to the strain gauge is zero.

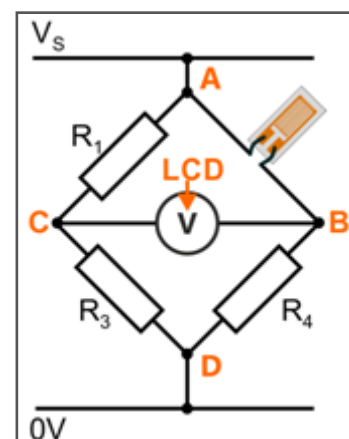

## Introduction:

# Structures Bending stress

### The apparatus:

consists of a beam, supported at two points, with a block of four strain gauged at its centre, two glued on top of the beam and two glued underneath.

The apparatus is designed to work off 5v power supply. This means that a USB cable plugged into either a computer or a plug will be sufficient. The data acquisition software only works through the computer, therefore the recommended setup is to have the USB plugged into the computer which is running the software. However, if you'd like to run the experiment without the software, a USB plug will need to be being sourced for the correct local plug style.

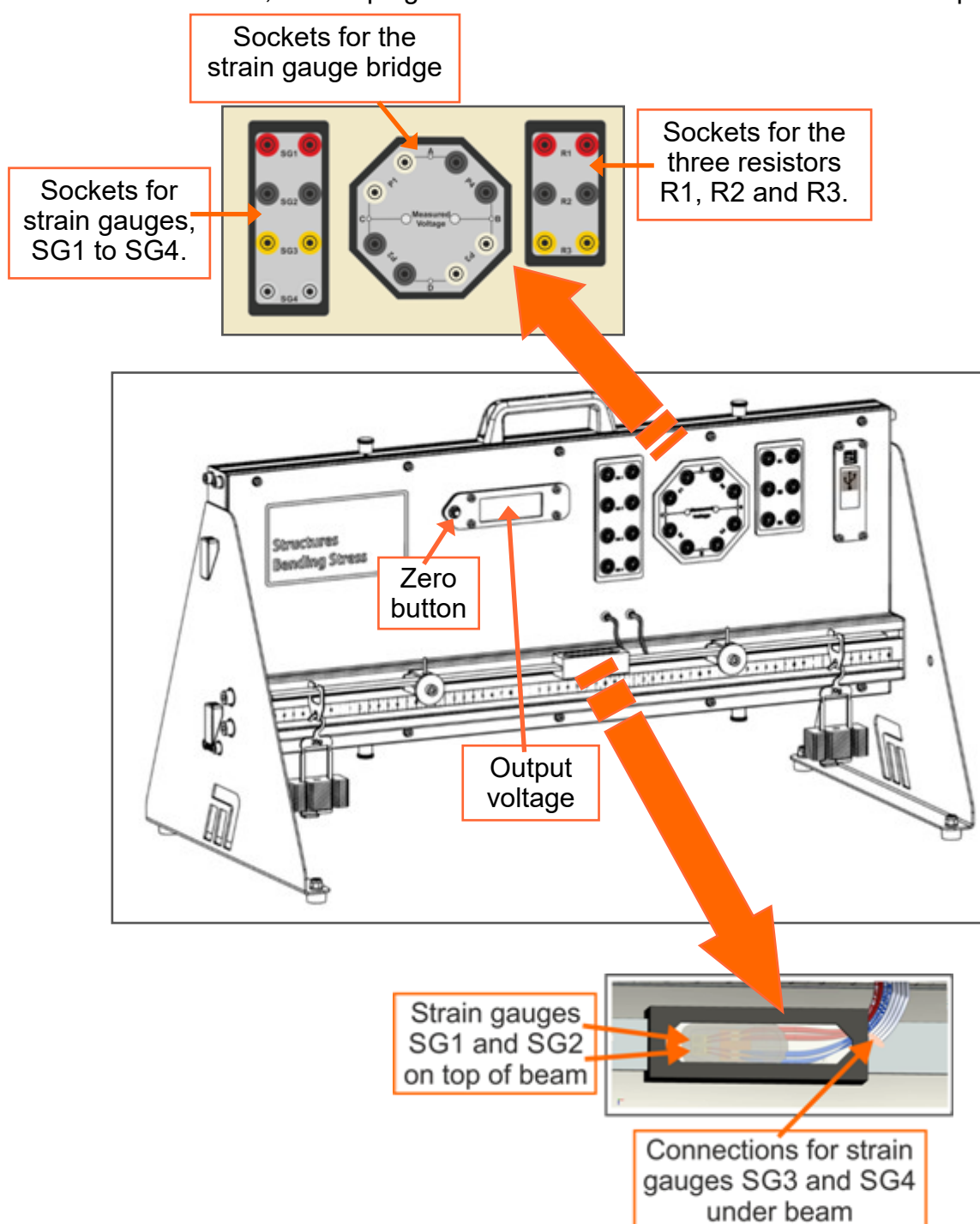

# Worksheet 1

## The quarter bridge

# Structures

## Bending stress

The quarter bridge is the simplest type of strain gauge bridge.

It is the one shown in the circuit diagram at the bottom of page 5. One of the four resistors in the Wheatstone bridge is replaced by a strain gauge.

The picture opposite shows one way to implement this.

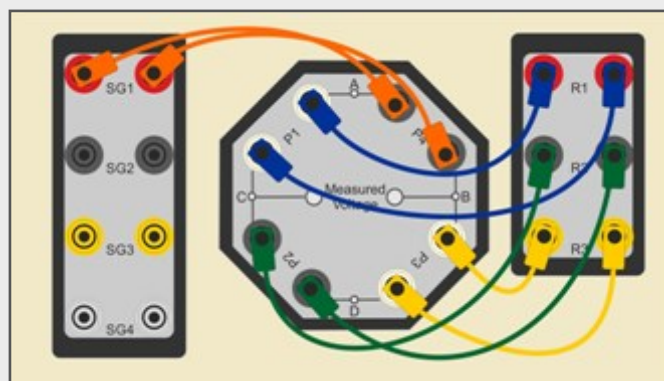

### Over to you:

- Make the following connections:
  - strain gauge **SG1** to **P4** sockets;
  - resistor **R1** to **P1** sockets;
  - resistor **R2** to **P2** sockets;
  - resistor **R3** to **P3** sockets.
- Power up the equipment by connecting the USB port at the right-hand end of the panel to either a PC port or a plug-in power supply, using the USB cable supplied. If connected via a PC port, data can be sent directly into a spreadsheet.
- As shown in the diagram, the supports are positioned 400mm apart. Place a hanger plate and empty mass hanger 50mm away from each support.

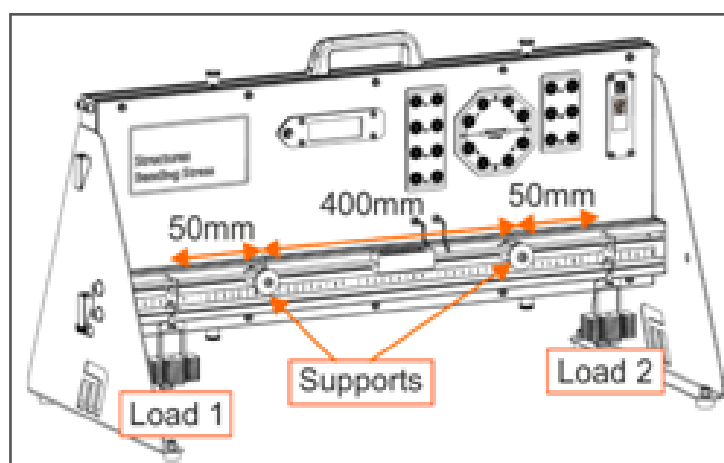

- Press the button on the LCD display to zero the equipment. This eliminates the weight of the beam and other components in later calculations.

# Worksheet 1

## The quarter bridge

# Structures

## Bending stress

### Over to you .....

- Carefully add a 20g mass to each hanger.
- Record the resulting LCD reading in the first row of the table in the Student Handout or on a spreadsheet. (The LCD screen turns green once the measurement has stabilised.)
- Continue in this way, adding 20g masses to each of the mass hangers and recording the LCD readings each time, up to a maximum total load of 400g (200g on each hanger).
- Record all results in the Student Handout or on a spreadsheet.
- Now, replace strain gauge **SG1** with strain gauge **SG2** and repeat the procedure.
- Next, do the same thing for strain gauges **SG3** and **SG4**.
- Plot graphs of LCD reading vs **total** suspended load for all four strain gauges, on the same set of axes provided in the Student Handout. The results should suggest a straight-line relationship for each graph.
- Answer the question about the polarity of the load cell readings.

### So What?

The quarter bridge configuration, with only one strain gauge, provides useful information about strain, but is limited to strain in one direction only.

Strain gauges are affected by changes in temperature . Their resistance wires expand or contract. As a result, their resistance changes, affecting the accuracy of the results.

Another limitation of the quarter bridge is that it cannot provide temperature compensation.

### Challenge:

- Investigate what happens when you move strain gauge **SG1** to each of the four positions, **P1**, **P2**, **P3** and **P4**, in turn, (keeping resistors in the other three bridge locations).
- Comment on your findings in the Student Handout.



# Worksheet 2

## The half bridge

# Structures

## Bending stress

The next configuration uses two strain gauges connected as shown in the bridge network.

In real-life applications, this arrangement offers greater sensitivity to applied stress and provide temperature compensation.

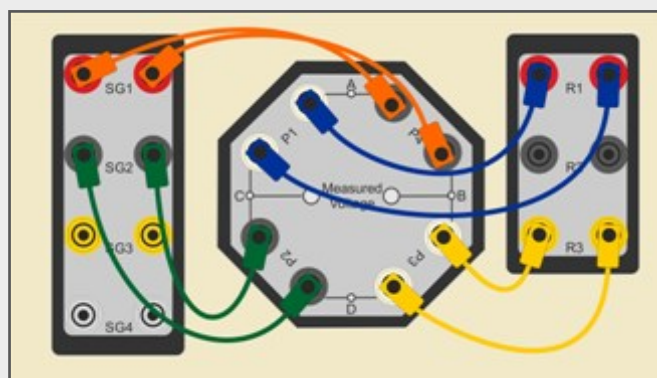

### Over to you:

- Make the following connections:
  - strain gauge **SG1** to **P4** sockets;
  - resistor **R1** to **P1** sockets;
  - strain gauge **SG2** to **P2** sockets;
  - resistor **R3** to **P3** sockets.
- The investigation mirrors that in worksheet 1.

After zeroing the LCD, slotted masses are added to the two mass hangers, 20g at a time up to a total of 400g (200g on each). The resulting LCD readings are recorded.

- Plot graphs of LCD reading vs **total** suspended load for the half bridge, on the axes provided in the Student Handout. Once again, the results should indicate a straight-line relationship.

# Worksheet 2

## The half bridge

# Structures

## Bending stress

### So What?

The half bridge network offers greater sensitivity to bending stress. The two strain gauges both change resistance, doubling the output voltage. (You can see this by comparing the gradients of the graphs for the quarter bridge and the half bridge.)

The half bridge network also offers compensation for temperature changes. Both strain gauges are subject to the same temperature changes and both expand or contract equally. When they are placed on opposite sides of the bridge network, these changes cancel out.

Placing the strain gauges parallel to each other like this allows measurement of longitudinal stress but not of axial loading. To achieve this, one strain gauge is placed at right angles to the other.

### Challenge:

- Investigate the effect of placing the strain gauges **SG1** and **SG2** in other positions around the bridge network.
- Comment on your findings in the Student Handout.

# Worksheet 3

## The full bridge

# Structures

## Bending stress

The next configuration uses all four strain gauges (and no resistors,) connected as shown in what is known as a full bridge network.

Its advantage is increased sensitivity.

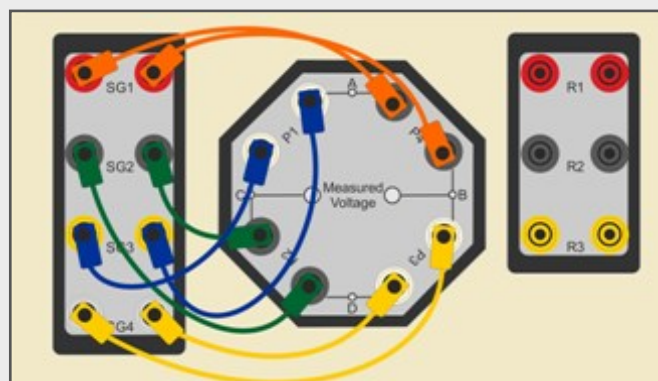

### Over to you:

- Make the following connections:
  - strain gauge **SG1** to **P4** sockets;
  - strain gauge **SG3** to **P1** sockets;
  - strain gauge **SG2** to **P2** sockets;
  - strain gauge **SG4** to **P3** sockets.
- Once again, the procedure is the same as that in worksheet 1.
 

After zeroing the LCD, slotted masses are added to the two mass hangers, 20g at a time up to a total of 400g (200g on each). The resulting LCD readings are recorded.
- Plot graphs of LCD reading vs **total** suspended load for the full bridge, on the axes provided in the Student Handout.
 

Again, the results should indicate a straight-line relationship.

# Worksheet 3

## The full bridge

# Structures

## Bending stress

### So What?

The full bridge has an even higher output signal, doubling the sensitivity of the half bridge.

All four strain gauges are subject to the same temperature changes and the effect of temperature on the bridge output voltage is further reduced.

The downside of the full bridge network can be its size. In some situations, it may not be possible to fix four strain gauges to the appropriate area of the structure.

### Challenge:

- Look at the graphs in worksheets 1, 2 and 3 for the quarter bridge, half bridge and full bridge performance.

Estimate the gradients for each and complete the table in the Student Handout with your findings.

- These results allow you to compare the sensitivities of the three types of bridge network. Comment on your comparison in the Student Handout.

# Worksheet 4

## Predicting the outcome

# Structures

## Bending stress

Measuring the effects of bending stress on practical equipment can be direct, real and immediate.

However, it is reassuring to be able to confirm the results through theory.

The process involves applying standard mechanical engineering concepts and formulae



The only forces acting on the beam are the reactions  $R_A$  and  $R_B$  at the supports and the two weights  $F_1$  and  $F_2$  on the mass hangers.

Here is the free body diagram for the system when the total load on the beam is 200g.

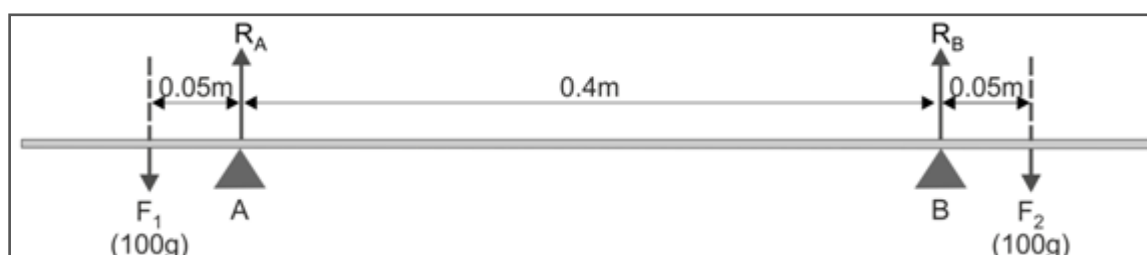

Using  $F = m \times g$

where  $F$  = force of gravity on a body,

$m$  = its mass (= 0.1kg)

$g$  = gravitational field strength (= 9.8N.kg<sup>-1</sup>)

$$F_1 = F_2 = 0.1 \times 9.8 = 0.98\text{N}$$

The system is in equilibrium.

Hence the following conditions must apply:

1. the sum of the vertical forces is zero;
2. the sum of the horizontal forces is zero (but here there are no horizontal forces);
3. the sum of the moments of forces around any point is zero.

# Worksheet 4

## Predicting the outcome

# Structures

## Bending stress

**Condition 1** gives us the equation

$$R_A + R_B = F_1 + F_2 = 0.98 + 0.98 = 1.96\text{N}$$

Applying **condition 3**:

Taking moments about support **A**:

$$F_2 \times 0.45 = (F_1 \times 0.05) + (R_B \times 0.4)$$

$$0.98 \times 0.45 = (0.98 \times 0.05) + (R_B \times 0.4)$$

$$R_B = 0.98\text{N}$$

From condition 1:

$$R_A = 1.96 - R_B = 0.98\text{N}$$

Next, we calculate the **bending moments**  $M_A$  and  $M_B$  at supports **A** and **B**.

At support **A**:

$$M_A + F_1 \times 0.05 = 0$$

$$M_A = -0.98 \times 0.05 = -0.049\text{Nm}$$

As the beam is in equilibrium, this is opposed by an equal bending moment at support **B**.

Hence:

$$M_B = +0.049\text{Nm}$$

The **maximum deflection** of the beam,  $\delta_{\max}$ , is given by the formula:

$$\delta_{\max} = \frac{M \times L^2}{8 \times E \times I}$$

where

**M** = bending moment (= 0.049Nm)

**L** = distance between supports (= 0.4m)

**E** = Young's modulus (= 73GPa)

**I** = second moment of inertia of beam (=  $6.914 \times 10^{-11}\text{m}^4$ )

$$\delta_{\max} = \frac{0.049 \times 0.4^2}{8 \times 73 \times 10^9 \times 6.914 \times 10^{-11}}$$

$$= 0.19\text{mm}$$

# Worksheet 4

## Predicting the outcome

# Structures

## Bending stress

Then using the formula for **stress**,  $\sigma$ :

$$\sigma = \frac{M \times y}{I} \quad \text{where } y = \text{distance from neutral axis} = 0.00185\text{m}$$

In this case,  $y$  is equal to half the height of the beam, which is 3.7mm.

$$\begin{aligned} \sigma &= \frac{0.049 \times 0.00185}{6.914 \times 10^{-11}} \\ &= 1.31\text{MPa} \end{aligned}$$

From the definition of Young's modulus, **tensile strain**  $\varepsilon = \frac{\sigma}{E} = \frac{1.31 \times 10^6}{73 \times 10^9}$   
 $= 1.8 \times 10^{-5}$

By definition **strain gauge factor**, **GF**, is the ratio of relative change in electrical resistance to mechanical strain,

i.e.

$$\text{GF} = \frac{\Delta R / R}{\varepsilon}$$

The strain gauges used in this apparatus have a gauge factor of 2.03 and a resistance of 350 $\Omega$ . Hence, the **change in resistance**,  $\Delta R$ , expected from the applied stress  $\sigma$  is:

$$\Delta R = \varepsilon \times R \times \text{GF} = 1.8 \times 10^{-5} \times 350 \times 2.03 = 0.013\Omega$$

# Worksheet 4

## Predicting the outcome

# Structures

## Bending stress

When under this stress, the strain gauge will then have a resistance,  $R_{SG}$  of

$$R_{SG} = (350 + 0.013) = 350.013\Omega.$$

It is in series with a  $350\Omega$  resistor,  $R$  and together they share the 5V power supply.

With no strain applied,  $V_{OUT} = 2.5V$

When the bending stress is applied, the output voltage changes to

$$\begin{aligned} V'_{OUT} &= V_S \times R / (R + R_{SG}) = 5 \times 350 / (350 + 350.013) \\ &= 2.49995V \end{aligned}$$

The **change in output voltage**,  $\Delta V$ , caused by the bending stress is given by:

$$\Delta V = (2.5 - 2.49995) = 0.00005V = 0.05mV$$

### Challenge:

- Repeat these steps for total loads of 80g and 320g to work out the theoretical change in LCD reading for these loads.
- Complete the table in the Student Handout with your results.
- Compare these results with those obtained experimentally in worksheet 1.
- Comment on this comparison and on the importance of reading errors in the Student Handout.

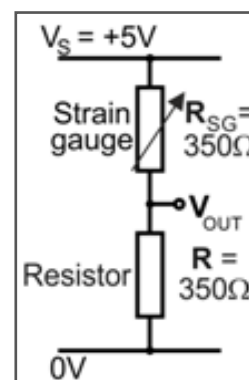



**Student  
Handout**

# Bending stress worksheets

## Worksheet 1 - The quarter bridge

Total mass in g	LCD reading in mV			
	SG1	SG2	SG3	SG4
40				
80				
120				
160				
200				
240				
280				
320				
360				
400				

### LCD reading vs total load graph:

Plot your results for all four strain gauges on the same set of axes.

Choose a suitable scale for the 'LCD reading' axis.

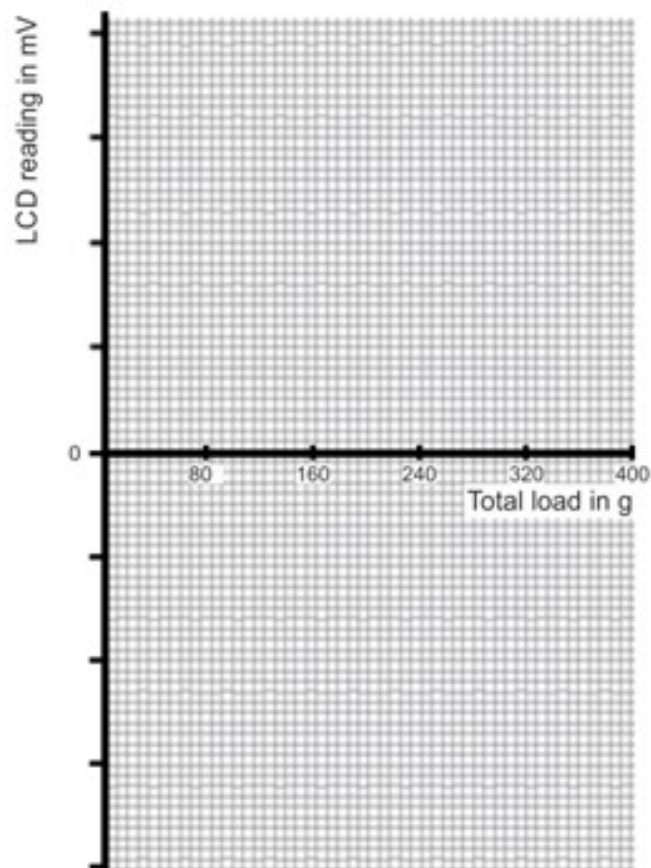

# Bending stress worksheets

## Worksheet 1 .....

Why does the LCD reading polarity change for some of the strain gauges?

.....  
.....  
.....  
.....  
.....  
.....  
.....

## Challenge:

What happens when you connect strain gauge **SG1** in each of the four positions around the bridge network?

Comment on your findings.

.....  
.....  
.....  
.....  
.....  
.....  
.....  
.....  
.....  
.....

# Bending stress worksheets

## Worksheet 2 - The half bridge

Total mass in g	LCD reading in mV
40	
80	
120	
160	
200	
240	
280	
320	
360	
400	

### LCD reading vs total load graph:

Plot your results for the half bridge on the axes below.

Choose a suitable scale for the 'LCD reading' axis.

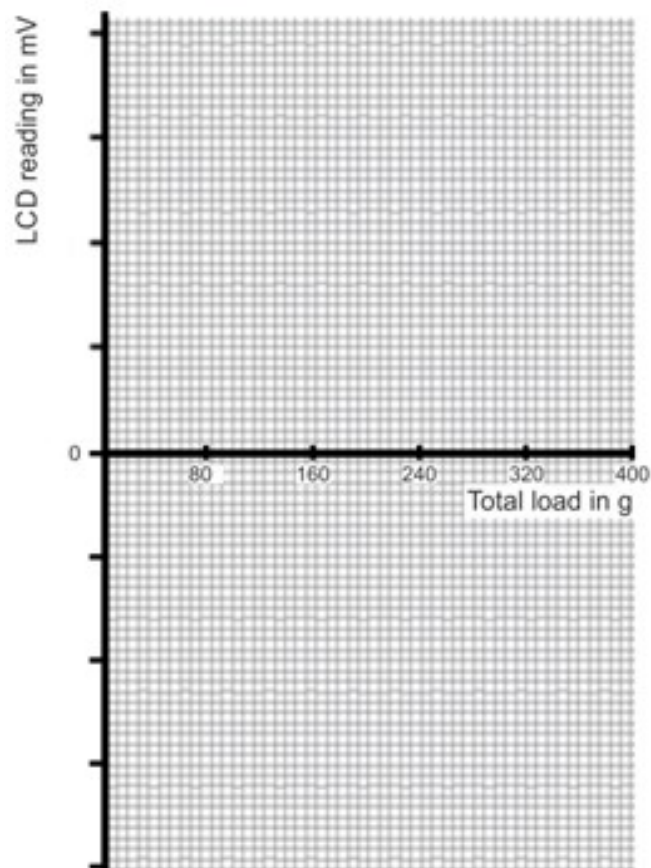



# Bending stress worksheets

## Worksheet 3 - The full bridge

Total mass in g	LCD reading in mV
40	
80	
120	
160	
200	
240	
280	
320	
360	
400	

### LCD reading vs total load graph:

Plot your results for the full bridge on the axes below.

Choose a suitable scale for the 'LCD reading' axis.

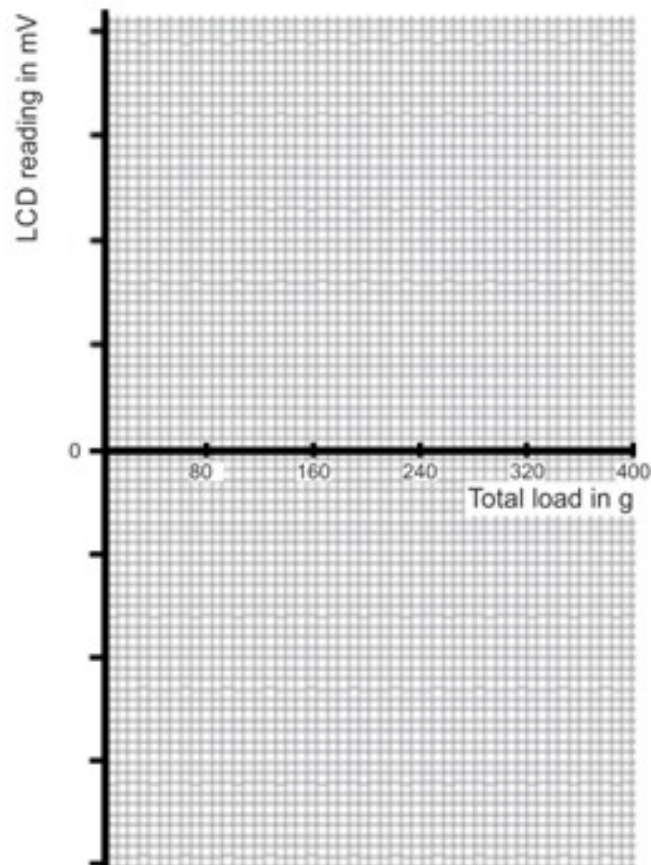







**Notes  
for the  
Instructor**

### About this course

#### Introduction

The 'Structures - Bending stress' module introduces students to the use of three types of strain gauge bridge to examine the results of applying a load to a beam.

Using the kit, students complete a series of worksheets that focus on a number of topics found in BTEC Higher National and equivalent courses. Initially, these worksheets provide full details of the investigations. Eventually, that 'scaffolding' is reduced, encouraging students to demonstrate their knowledge and understanding to new situations.

#### Aim

The course teaches students about the relationships between applied loads and the resulting bending stress.

#### Prior Knowledge

It is expected that students have followed an introductory science course, enabling them to take, record and analyse scientific observations. Some mathematical capability is required - ability to take readings from an analogue scale, ability to understand the transposition of formulae, ability to use a calculator to perform calculations and ability to plot a graph.

#### Using this course:

It is expected that the Worksheets and Student Handout are printed / photocopied, preferably in colour, for the students' use.

The Student Handout is a record of measurements taken in each worksheet and questions relating to them. Students do not need a permanent copy of the worksheets but do require their own copy of the Student Handout.

This format encourages self-study, with students working at a rate that suits their ability. It is for the instructor to monitor that their understanding is keeping pace with progress through the worksheets. One way to do this is to 'sign off' each worksheet, as the student completes it, and in the process have a brief chat to assess the student's grasp of the ideas involved in the exercises it contains.

We realise that you as a subject area practitioner are the lead in determining how and what students learn. The worksheets are not meant to supplant this or any other supporting underpinning knowledge you choose to deliver.

For subject experts, the 'Notes for Instructors' are provided simply to reveal the thinking behind the approach taken. For staff whose core subject knowledge is not in the field covered by the course, these notes can both illuminate and offer guidance.

#### Time:

It will take students between three and five hours to complete the worksheets.

A similar length of time will be needed to support the learning that takes place as a result.

### Learning Objectives

On successful completion of this course, the student will be able to:

- draw the circuit diagram for a Wheatstone bridge;
- derive the formula linking the resistors found in the Wheatstone bridge;
- explain what is meant by a 'balanced' bridge;
- describe the structure of one type of resistive strain gauge;
- explain the changes in resistance that take place when such a strain gauge is subjected to bending stress;
- draw the circuit diagram for the following types of strain gauge bridge:
  - quarter bridge;
  - half bridge;
  - full bridge.
- connect strain gauges and resistors to create these types of strain gauge bridge;
- state two advantages of the half and full bridge network over the quarter bridge network;
- explain the need to 'zero' the LCD display before taking readings;
- explain why some readings of output voltage are positive while others are negative;
- draw a free body diagram to represent the forces acting on the beam in this apparatus;
- state three consequences of the beam being in equilibrium;
- calculate the moment of a force about some point in the apparatus;
- use the equilibrium conditions and principle of moments to obtain values for the bending moments at the two beam supports;
- use the following formulae to obtain a theoretical estimate of the output from the quarter bridge:
  - $\delta_{\max} = \frac{M \times L^2}{8 \times E \times I}$
  - $\sigma = \frac{M \times y}{I}$
  - $\epsilon = \frac{\sigma}{E}$
  - $\Delta R = \epsilon \times R \times GF$

# Notes for the instructor

# Structures

## Bending stress

Worksheet	Notes
<p><b>Introduction</b></p> <p>Timing 15 - 20 mins</p>	<p>Concepts involved: <i>Wheatstone bridge    voltage divider    strain gauge</i> <i>factors affecting resistance of a conductor</i></p> <p>The introduction starts with the Wheatstone bridge. Students with a limited electrical theory background may need help in understanding the bridge network. Looking at it as two voltage dividers may help in this. The idea of a balanced bridge may need further explanation. Students need to realise that the output voltage of the bridge is displayed on the LCD.</p> <p>The instructor could expand on the factors affecting the resistance of a conductor (length, cross-sectional area especially,) in introducing the working of the strain gauges. Some students may need numerical examples to illustrate the working of the strain gauge bridge.</p> <p>An overview of the layout of the apparatus may reduce the number of connecting errors later.</p>
<p><b>1</b> <b>The quarter bridge</b></p> <p>Timing 30 - 45 mins</p>	<p>Concepts involved: <i>quarter bridge    resistance and temperature    mass</i> <i>weight    gravitational field strength</i></p> <p>The first hurdle is the correct wiring of the bridge network. If not done, previously, the instructor should point out the position of the strain gauges on the beam, as students need this information to work out the answer to the question posed about the polarity of the measurement and to make sense of the challenge results.</p> <p>The perennial problem is the distinction between mass and weight. Instructors should stress that the terms cannot be used interchangeably.</p> <p>Instructors may wish to check that students understand the significance of <i>total load</i>.</p>
<p><b>2</b> <b>The half bridge</b></p> <p>Timing 30 - 45 mins</p>	<p>Concepts involved: <i>half bridge    sensitivity    longitudinal vs axial loading</i></p> <p>Instructors should check the wiring of the bridge to ensure that the strain gauges are connected in different arms of the bridge.</p> <p>Students are not given step-by-step instructions for this investigation but are simply told that it 'mirrors that in worksheet 1'. It is expected that they are of such a calibre that they can do this.</p> <p>The issue of direction of loading is raised in the summary and may need further reinforcement from the instructor.</p>

# Notes for the instructor

# Structures

## Bending stress

Worksheet	Notes
<p><b>3</b> <b>The full bridge</b></p> <p>Timing 40 - 60 mins</p>	<p>Concepts involved: <i>full bridge</i></p> <p>The wiring task is actually simpler for this circuit. It does not matter which strain gauge is connected in what position!</p> <p>As in worksheet 2, students are not given step-by-step instructions but are simply told that it is the same as in worksheet 1.</p> <p>The challenge is to compare the sensitivities of the three types of strain gauge bridge circuit. This could be done as a group presentation to the class.</p>
<p><b>4</b> <b>Predicting the outcome</b></p> <p>Timing 40 - 60 mins</p>	<p>Concepts involved: <i>free body diagram    equilibrium    moment of a force    Young's modulus</i> <i>second moment of inertia    tensile stress    tensile strain</i> <i>strain gauge factor    voltage divider formula</i></p> <p>The process involved in deriving theoretical values for the output voltage involves a number of stages and is complicated. It is not expected that students recall it from memory but they should be able to follow it in the notes.</p> <p>The stages are indicated by bold type and the results are enclosed in red boxes.</p> <p>The challenge is to work out the theoretical output voltage for two other values of load. Where students have used a spreadsheet, then it is worthwhile asking them to derive theoretical outputs for all values of load.</p>