

STRUCTURES

Pin Jointed Frameworks



MATRIX

CP8026

www.matrixsl.com

Copyright © 2021 Matrix Technology Solutions Limited

Contents

Structures

Pin-jointed frame

Pin-jointed frame

Introduction	7
Worksheet - Check the loading	6
Investigation A - Load applied to joint P	7
Calculating the forces - method of joints	8
Calculating the forces - method of sections	11
Investigation B - Load applied to joint R	13
Investigation C - Multiple loads	14
Summary	15
Student Handout	16
Notes for the instructor	21

Introduction:

Structures Pin-jointed frame

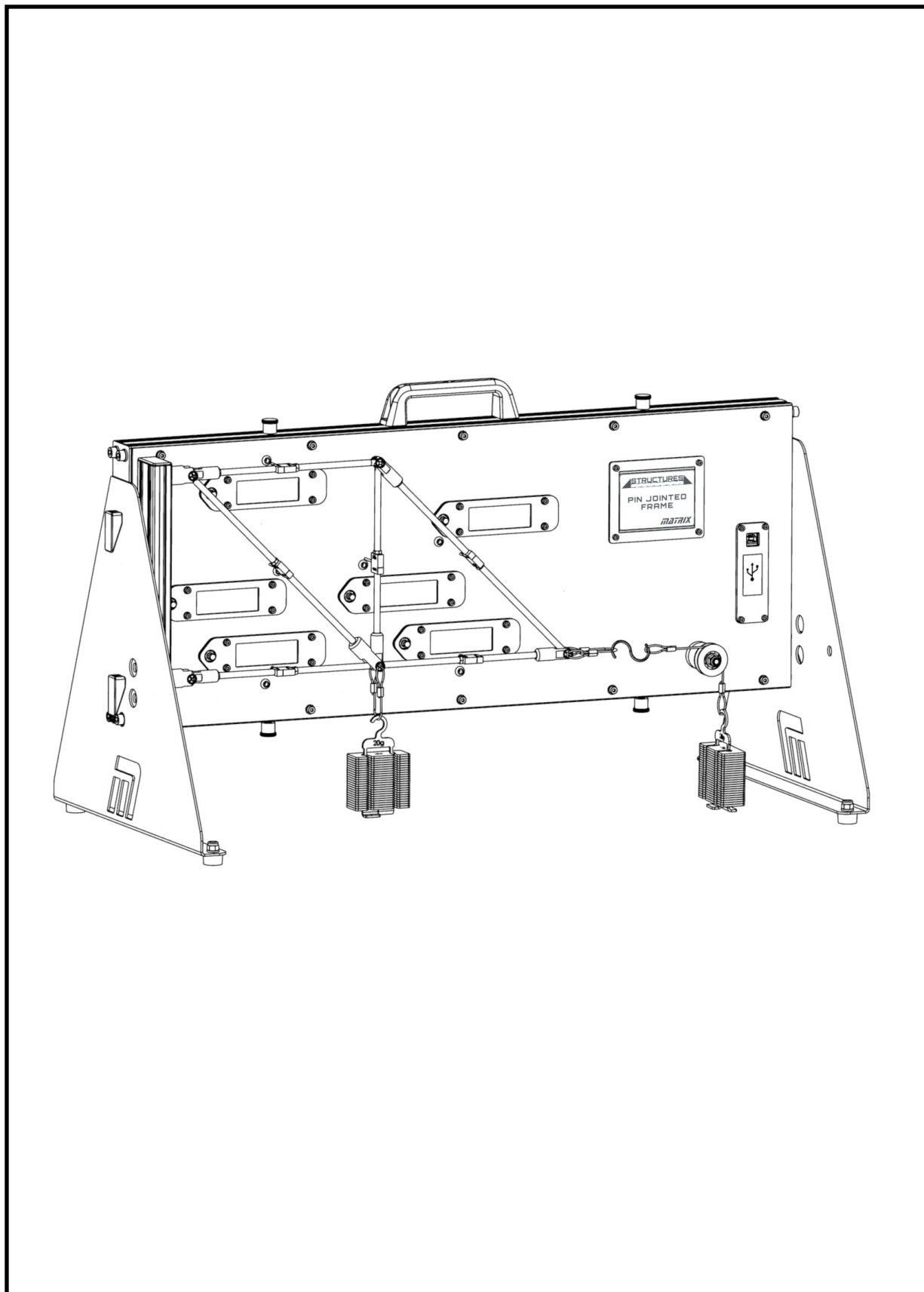

Introduction:

Structures Pin-jointed frame

These investigations examine the load distribution within a structural framework, consisting of six members linked by pin joints.

A pin joint can resist both vertical and horizontal forces but not a moment. It has only one degree of freedom, allowing rotation about a single axis but no translational motion.

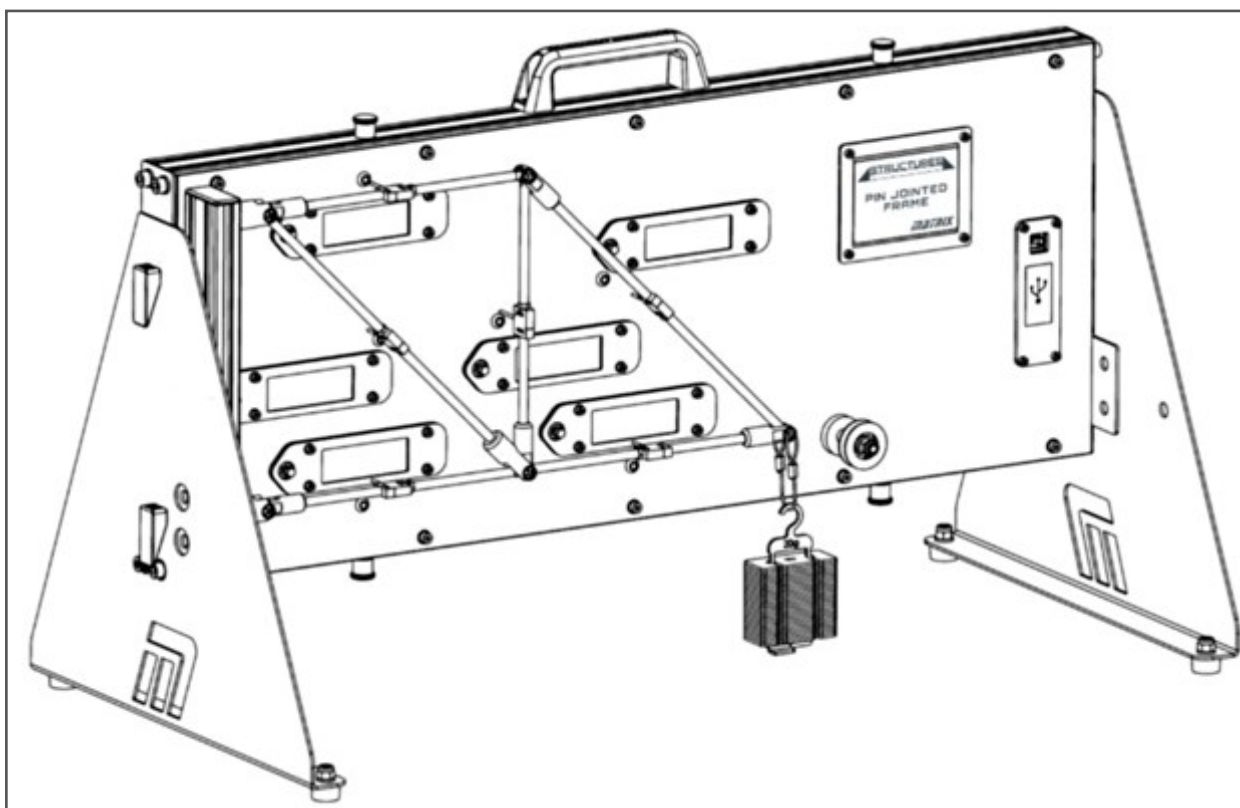

The framework is fixed at the left-hand end to an aluminium beam simulating a reaction wall. Each stainless steel member has at its mid-point a load cell linked to a LCD display. These displays measure the tension / compression force within each member. A negative reading on the load cell indicates a tension force in the member.

In this module, it is used to allow the student to check forces calculated from theory against measured values.

The apparatus is designed to work off 5v power supply. This means that a USB cable plugged into either a computer or a plug will be sufficient. The data acquisition software only works through the computer, therefore the recommended setup is to have the USB plugged into the computer which is running the software. However, if you'd like to run the experiment without the software, a USB plug will need to be sourced for the correct local plug style.

Introduction:

Structures Pin-jointed frame

Bow's notation, a labelling convention, is used to label the free body diagrams. The spaces around the members are labelled **A** to **G**. The members, and the forces within them, have labels that indicate the spaces that they separate.

The first diagram shows the labelling of the six members, using this convention.

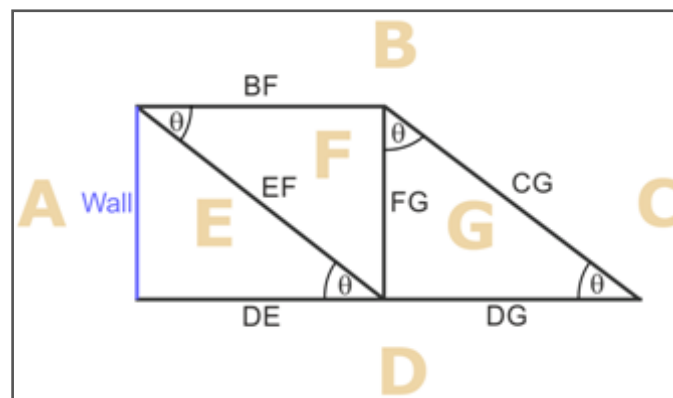

The second diagram identifies the forces acting within those members.

In addition, it shows the external forces:

- added load **W**;
- reaction forces **R₁** and **R₂** generated at the reaction wall. These are shown resolved into horizontal and vertical components, e.g. **R_{1X}** and **R_{1Y}**.

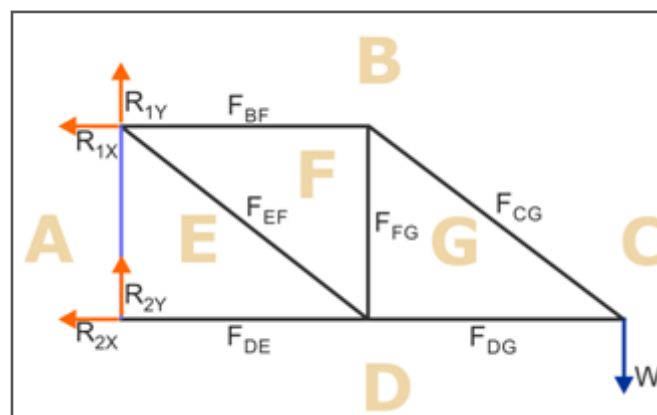

Worksheet

Check the loading!

Structures

Pin-jointed frame

The engineer designing a frame structure must analyse the loading of each member in it over the full range of loads expected.



Some members will be in compression while others are in tension. Some are zero force members, with no internal forces at all, used to increase the stability and rigidity of the structure.

Different materials have different properties. Some perform better under compression, while others are better under tension. This analysis helps to select appropriate materials and determine suitable dimensions.

The experiments in this module allow us to compare calculated values of the forces in the beams and columns with measured values. The aim is to validate the techniques used in the calculations.

Investigation A

Load applied to joint P

Structures

Pin-jointed frame

In each investigation:

- Make sure that the device is level.
 - The diagram numbers each of the six LCD displays to allow you to record their readings in the Student Handout.
 - Before you start, press the button on the LCD display to zero the load cells. The displays will turn green when they have done so. This removes the weight of the frame from later readings.
 - Readings can either be taken manually or by using data transfer via the USB port directly to a spreadsheet
 - The displays show the loads in grammes. To obtain the load as a force, in newtons:
 - divide the reading by 1000 to convert it into kilogrammes;
 - multiply the result by 9.81, the gravitational field strength.
- You now have the load expressed as a force.

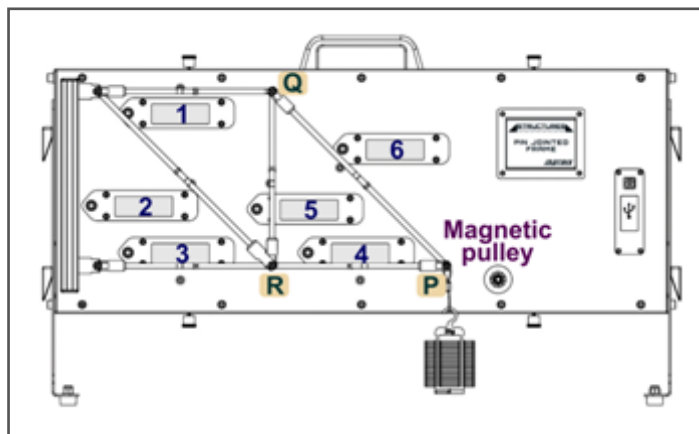

Investigation A

Over to you:

- As shown in the diagram on the previous page, suspend an empty mass hanger from joint **P** on the frame, using a loop of string. The empty hanger has a mass of 20g.
- Take each load cell reading and convert it into the force within that member, as described above. Record it in the table in the Student Handout. The table identifies the frame member corresponding to each load cell.
- Increase the load by adding a 40g mass to the mass hanger and record the new readings.
- Continue in this way until the mass hanger carries a total of 300g.
- Next, measure the angle θ between the frame members at joint **P**, and the lengths X and Y of members DG and FG .
- Record them in the Student Handout for use in later calculations.
- Calculate the forces in each member, using one of the methods outlined in the following pages.
- Record your results in the second table in the Student Handout.

Calculating the forces:

1. Method of joints

Structures

Pin-jointed frame

Calculating the forces

There are two approaches to finding the theoretical values of the forces in the members:

- the method of sections;
- the method of joints.

Both rely on the same basic physics - in a body that is equilibrium:

1. the total horizontal force is zero;
2. the total vertical force is zero;
3. the sum of the moments of forces about any point is zero.

Method of joints:

This looks at the forces acting on a particular joint.

For example, first of all, concentrate on the forces acting on the joint labelled **P**.

The second diagram makes assumes that:

- force F_{CG} is a tension force;
- force F_{DG} is compressing joint P.

These assumptions are not significant as the maths will identify the true directions by adding a '+' or a '-' sign.

The diagram also shows force F_{CG} resolved into horizontal and vertical components.

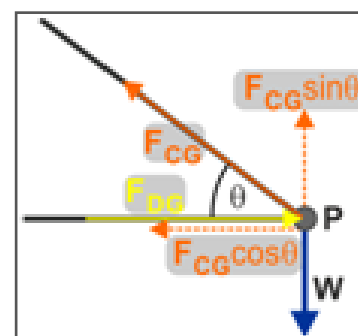
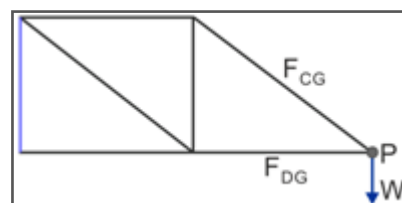

The analysis

1. Sum of vertical forces = 0:

$$F_{CG} \sin \theta - W = 0$$

$$F_{CG} = W / \sin \theta$$

2. Sum of horizontal forces = 0:

$$F_{DG} - F_{CG} \cos \theta = 0$$

$$\text{so } F_{DG} = F_{CG} \cos \theta$$

3. Sum of the moments of forces is zero:

No useful equation will be obtained by taking moments about point **P** as both F_{CG} and F_{DG} , pass through that point and so exert no moment about it.

Knowing the load W and the angle θ , the two forces F_{CG} and F_{DG} can be determined.

Calculating the forces: 1. Method of joints

Structures Pin-jointed frame

Joint Q:

Next, look at the forces acting on joint **Q**.

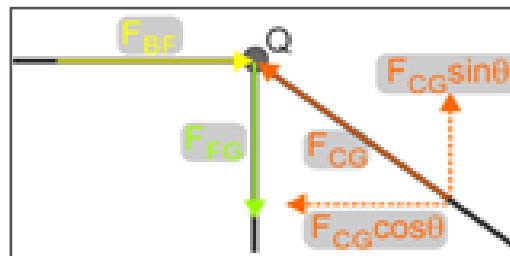
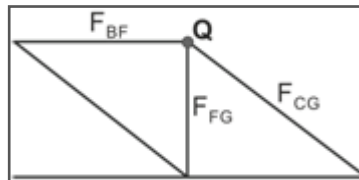

Force F_{CG} is again resolved into horizontal and vertical components.

The analysis

1. Sum of vertical forces = 0:

$$F_{CG} \sin \theta - F_{FG} = 0$$

$$F_{FG} = F_{CG} \sin \theta$$

2. Sum of horizontal forces = 0:

$$F_{BF} - F_{CG} \cos \theta = 0$$

$$F_{BF} = F_{CG} \cos \theta$$

3. Sum of the moments of forces is zero:

Once again, as all three forces pass through point **Q**, no useful equation results from taking moments about point **Q**.

Knowing force F_{CG} and the angle θ , the two forces F_{FG} and F_{BF} can be found.

Calculating the forces:

1. Method of joints

Structures

Pin-jointed frame

Joint R:

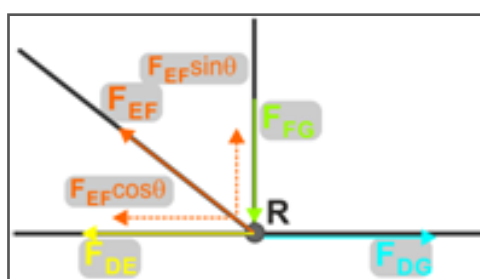
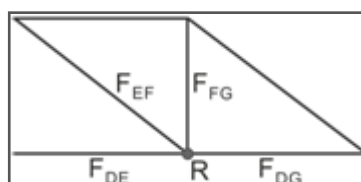

This time, force F_{EF} is resolved into horizontal and vertical components.

solved into horizontal

The analysis

1. Sum of vertical forces = 0:

$$F_{EF} \sin \theta - F_{FG} = 0$$

$$F_{EF} = F_{FG} / \sin \theta$$

2. Sum of horizontal forces = 0:

$$F_{DG} - F_{EF} \cos \theta - F_{DE} = 0$$

$$F_{DE} = F_{DG} - F_{EF} \cos \theta$$

3. Sum of the moments of forces is zero:

Again, all forces pass through point **R** and so no useful equation results from taking moments about point **R**.

Knowing forces F_{FG} and F_{DG} and the angle θ , the two forces F_{EF} and F_{DE} can be found.

Summary

By analysing the situations at the joints, **P**, **Q** and **R**, all six forces have been calculated. Notice that at each joint the analysis yields only two equations, as taking moments was pointless. As a result, the analysis of each joint worked because there were only two unknown forces involved each time.

This method is not appropriate when more than two unknown forces act on the joint.

Calculating the forces: 2. Method of sections

Structures Pin-jointed frame

Method of sections:

This approach examines the forces acting on a particular section of the structure.

A cut through the structure creates that section. Like the whole structure, the section is in equilibrium and so in that section:

- the sum of the vertical forces is zero;
- the sum of the horizontal forces is zero
- and the sum of the moments of the forces around any point is zero.

This time, each of these aspects will generate a useful equation, meaning that we can cope with **three** unknown forces within the section we choose.

A theoretical cut can only go through 3 unknown members.

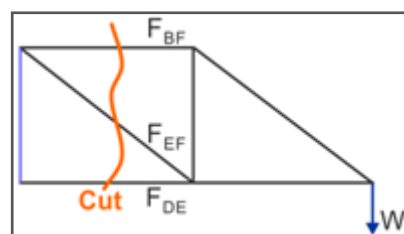

For example, look at the section created by cutting through members **BF**, **EF** and **DE**, as shown opposite.

This will allow us to determine the forces **F_{BF}**, **F_{EF}** and **F_{DE}**.

Step 1 - draw the free body diagram for the section:

All the forces have been drawn in tension, but again the maths will sort out whether that is true or not.

Force **F_{EF}** is shown resolved into its horizontal and vertical components.

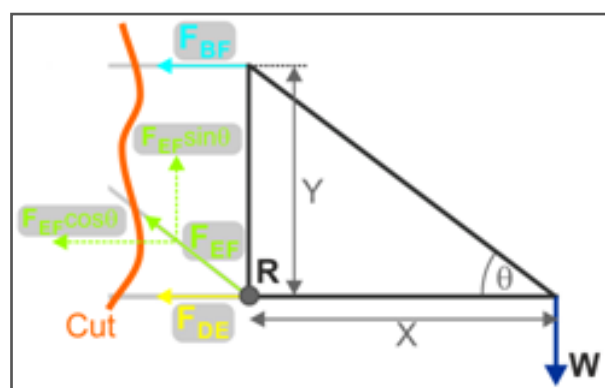

Step 2 - apply the equilibrium criteria:

Looking at the vertical forces: $F_{EF} \sin \theta - W = 0$

and so $F_{EF} = W / \sin \theta$

Taking moments about joint **R**: $(F_{BF} \cdot Y) - (W \cdot X) = 0$

and so $F_{BF} = W \cdot X / Y$

Looking at the horizontal forces: $-F_{DE} - F_{BF} - F_{EF} \cos \theta = 0$

and so $F_{DE} = -F_{BF} - F_{EF} \cos \theta$

Knowing **W**, **θ** and the lengths **X** and **Y** allows us to calculate the three forces.

Calculating the forces: 2. Method of sections

Structures Pin-jointed frame

Next, look at the section created by cutting through members **CG** and **DG**.

This allows us to determine the forces F_{CG} and F_{DG} .

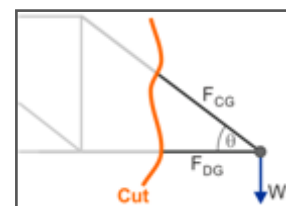

Step 1 - draw the free body diagram for the section:

Force F_{CG} is shown resolved into its horizontal and vertical components.

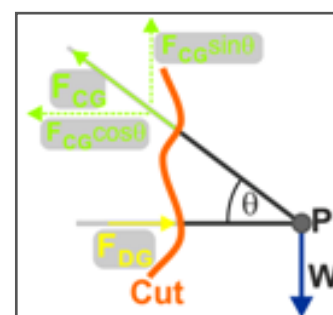

Step 2 - apply the equilibrium criteria:

Looking at the vertical forces: $F_{CG} \sin \theta - W = 0$

and so $F_{CG} = W / \sin \theta$

Looking at the horizontal forces: $F_{DG} - F_{CG} \cos \theta = 0$

and so $F_{DG} = F_{CG} \cos \theta$

There is no need for a third equation as there are only two unknown forces.

Knowing W and θ , these forces can be determined.

That leaves only one unknown force, F_{FG} . This can be obtained using the method of joints, looking at joint **Q** or **R**, or by applying another cut as shown below:

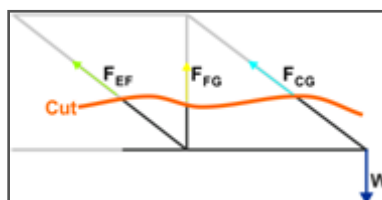

Although this shows that there are three forces involved, two, F_{EF} and F_{CG} , are already known. The remaining one, F_{FG} , can be determined by looking at the vertical forces.

Summary

The method of sections generates a maximum of **three** equations and so cannot be used for a cut involving more than **three** unknown forces.

Investigation B

Load applied to joint R

Structures

Pin-jointed frame

Investigation B

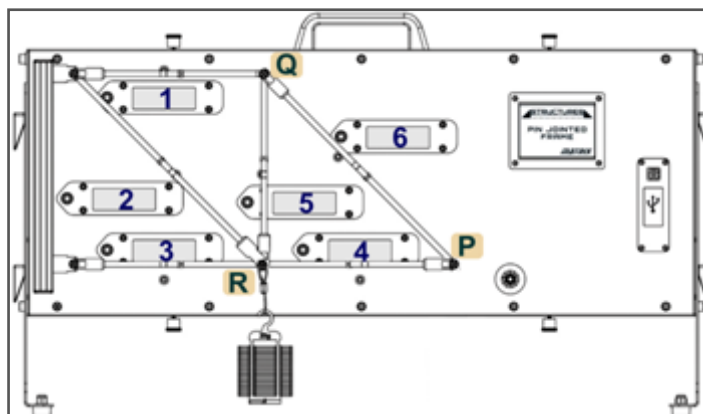

Over to you:

- Move the mass hanger from joint **P** to joint **R** on the frame.
- With the mass hanger empty, (i.e. mass 20g,) take each load cell reading and convert it into the equivalent force.
Record it in the table in the Student Handout.
- As before, increase the load in 40g steps until the total mass of the load is 300g, recording the load cell readings as forces each time.

Challenge:

- Use the method of joints analysis given on pages 8 to 10 to obtain equations for the forces in the six members of the frame with the load at joint **R**.
- Give your analysis in the space provided in the Student Handout.
- Hence, calculate the forces in each member.
(Hint - you will find that there are some zero force members.)
- Record your results in the second table in the Student Handout.

Investigation C

Multiple loads

Structures

Pin-jointed frame

Investigation C

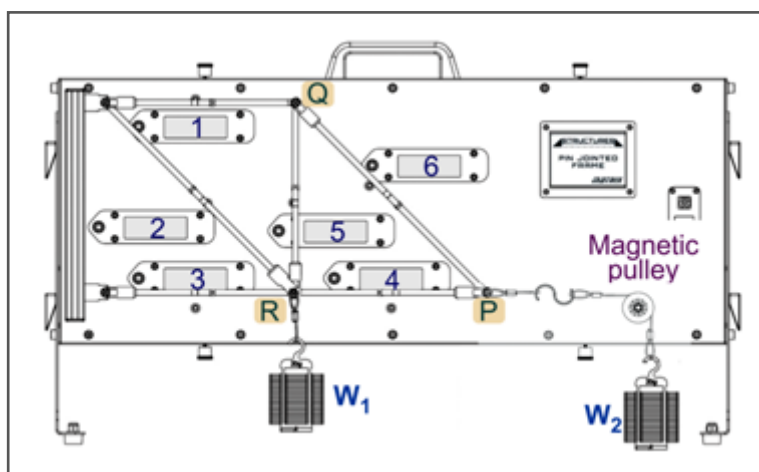

Over to you:

- With one mass hanger still attached to joint **R**, add a second one to joint **P** but using the magnetic pulley to apply the load at an angle, as shown above.
- The table in the Student Handout suggests values for **W₁** and **W₂** and the angle θ at which **W₂** is applied.
Load the mass hangers with the chosen values of weights and move the magnetic pulley to set the desired angle.
- Each time, take each load cell reading and convert it into the equivalent force.
Record it in the table in the Student Handout.

Challenge:

- Using one of the methods outlined earlier, draw free body diagrams and use them to obtain equations for the forces in the six members of the frame when loaded in this way.
- Present your diagrams and analysis in the space provided in the Student Handout.
- Hence, calculate the forces in each member.
- Record your results in the second table in the Student Handout.

Summary

Structures

Pin-jointed frame

So what:

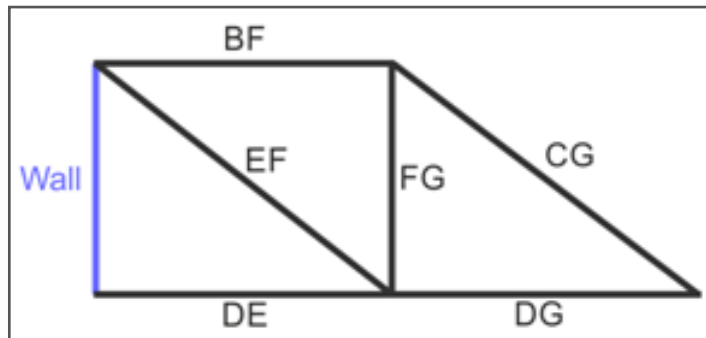

- Triangulated frameworks like this are often used in structures such as bridges and roof supports. Their analysis and design can be greatly simplified by treating the joints as pin joints.
- The positions and sizes of external forces such as loads and reaction forces determine the loading pattern across a structure. Analysis like that shown here can optimise designs and identify zero force structural members.
- Topology optimization is the mathematical technique used to refine the design of a structure within specified boundary conditions. The pin jointed frame above could be used in this kind of analysis to reduce the number of beam elements depending on the loading conditions.
- The loading pattern can have a big effect on the force within a structural member. The angle at which a load is applied can determine whether a member is in tension or compression. This can then influence the choice of material for that member. For example, wood is 30% stronger under compression than in tension.

**Student
Handout**

Pin-jointed frame worksheets

Investigation A - Load applied to joint P

Mass of load in g	Weight W of load in N	Measured force, in N, in member:					
		F_{BF}	F_{EF}	F_{DE}	F_{DG}	F_{FG}	F_{CG}
		Load cell 1 in N	Load cell 2 in N	Load cell 3 in N	Load cell 4 in N	Load cell 5 in N	Load cell 6 in N
0	0	0	0	0	0	0	0
20	0.20						
60	0.59						
100	0.98						
140	1.37						
180	1.77						
220	2.16						
260	2.55						
300	2.94						

Angle θ between the frame members at joint **P** =

Length of member DG, X =

Length of member FG, Y =

Mass of load in g	Weight W of load in N	Calculated force, in N, in member:					
		F_{BF}	F_{EF}	F_{DE}	F_{DG}	F_{FG}	F_{CG}
0	0	0	0	0	0	0	0
20	0.20						
60	0.59						
100	0.98						
140	1.37						
180	1.77						
220	2.16						
260	2.55						
300	2.94						

Pin-jointed frame worksheets

Investigation B - Load applied to joint R

Mass of load in g	Weight W of load in N	Calculated force, in N, in member:					
		F_{BF}	F_{EF}	F_{DE}	F_{DG}	F_{FG}	F_{CG}
0	0	0	0	0	0	0	0
20	0.20						
60	0.59						
100	0.98						
140	1.37						
180	1.77						
220	2.16						
260	2.55						
300	2.94						

Investigation C - Multiple loads

Mass of load 1 in g	Weight W1 of load 1 in N	Mass of load 2 in g	Weight W2 of load 2 in N	Load 2 angle θ'	Measured force, in N, in member:					
					F_{BF}	F_{EF}	F_{DE}	F_{DG}	F_{FG}	F_{CG}
					Load cell 1 in N	Load cell 2 in N	Load cell 3 in N	Load cell 4 in N	Load cell 5 in N	Load cell 6 in N
100	0.98	300	2.94	90						
100	0.98	300	2.94	45						
300	2.94	100	0.98	90						
300	2.94	100	0.98	45						

Mass of load 1 in g	Weight W1 of load 1 in N	Mass of load 2 in g	Weight W2 of load 2 in N	Load 2 angle θ'	Calculated force, in N, in member:					
					F_{BF}	F_{EF}	F_{DE}	F_{DG}	F_{FG}	F_{CG}
100	0.98	300	2.94	90						
100	0.98	300	2.94	45						
300	2.94	100	0.98	90						
300	2.94	100	0.98	45						

**Notes
for the
Instructor**

About this course

Introduction

The 'Structures - Pin-jointed frame' module introduces students to techniques for analysing loading of members of a frame structure.

Using the kit, students complete a series of tasks around topics found in BTEC Higher National and equivalent courses. Initially, students are given full details of the investigation. Eventually, that 'scaffolding' is reduced, encouraging students to apply and extend their knowledge to new situations.

Aim

The course teaches students about the relationships between applied loads and the resulting tensile and compressive forces within members of a frame structure.

Prior Knowledge

It is expected that students have followed an introductory science course, enabling them to take, record and analyse scientific observations. Some mathematical capability is required - ability to take readings from an analogue scale, ability to understand the transposition of formulae, ability to use a calculator to perform calculations and ability to plot a graph.

Using this course:

It is expected that the Worksheets and Student Handout are printed / photocopied, preferably in colour, for the students' use.

The Student Handout is a record of measurements taken in each worksheet and questions relating to them. Students do not need a permanent copy of the worksheets but do require their own copy of the Student Handout

This format encourages self-study, with students working at a rate that suits their ability. It is for the instructor to monitor that their understanding is keeping pace with progress through the worksheets. One way to do this is to 'sign off' each worksheet, as the student completes it, and in the process have a brief chat to assess the student's grasp of the ideas involved in the exercises it contains.

We realise that you as a subject area practitioner are the lead in determining how and what students learn. The worksheets are not meant to supplant this or any other supporting underpinning knowledge you choose to deliver.

For subject experts, the 'Notes for Instructors' are provided simply to reveal the thinking behind the approach taken. For staff whose core subject knowledge is not in the field covered by the course, these notes can both illuminate and offer guidance.

Time:

It will take students around three to four hours to complete the worksheets.

A similar length of time will be needed to support the learning that takes place as a result.

Learning Objectives

On successful completion of this course, the student will be able to:

- describe the meaning of the term 'pin joint';
- use Bow's notation to identify the members of a frame;
- explain what is meant by the term 'zero-force member';
- 'zero' a load cell;
- convert a load cell reading in grammes into a force in newtons;
- given data about the forces acting on members, draw and interpret a free-body diagram for the frame;
- resolve a force into perpendicular components;
- state that, for a body in equilibrium, the total force and total moment about any point is zero;
- calculate the moment of a given force about a given point;
- apply the method of joints to calculate forces in members in a frame;
- apply the method of sections to calculate forces in members in a frame;
- state the limitations of each method in terms of the number of unknown forces that can be determined.

Notes for the instructor

Structures Pin-jointed frame

Worksheet	Notes
<p>Introduction</p> <p>Timing 15 - 20 mins</p>	<p>Concepts involved: <i>load cell pin joint Bow's notation resolution of forces</i></p> <p>The introduction provides an overview of the equipment. It goes on to describe Bow's notation and applies it to the pin-jointed frame. The discussion includes a reference to the components of the reaction forces.</p> <p>Where students have not met this idea previously, the instructor may wish to expand on the details given with additional examples.</p>
<p>Check the loading!</p> <p>Timing 10 - 15 mins</p>	<p>Concepts involved: <i>tension compression zero force member</i></p> <p>The aim here is to explain the importance of calculating forces in the members of a framework. One consequence is the ability to select appropriate materials and dimensions for the members.</p>
<p>A Load applied to joint P</p> <p>Timing 20 - 35 mins</p>	<p>Concepts involved (optional): <i>mass weight gravitational field strength</i></p> <p>As this is the first time students have used this equipment, some may need guidance. In particular, the instructor should check that readings are recorded in the correct location in the table in the Student Handout.</p> <p>Depending on their mathematical ability and experience, some may need help in converting the load cell reading in grammes into a force in newtons.</p> <p>The discussion may widen to include the concepts mass, weight and gravitational field strength.</p>
<p>Calculating the forces: 1 Method of joints</p> <p>Timing 20 - 30 mins</p>	<p>This section starts with important ideas about the consequences of equilibrium. Unless students understand these, they will not follow the explanation of the method of joints!</p> <p>Where students are unfamiliar with free body diagrams, the instructor will need to support them by working through a number of examples.</p> <p>It may not be obvious that our initial decisions about the directions of action of the forces (tension or compression,) are not significant as the maths will point out where we are wrong. Some will need further guidance.</p>

Notes for the instructor

Structures Pin-jointed frame

Worksheet	Notes
<p>Calculating the forces:</p> <p>2 Method of sections</p> <p>Timing 20 - 30 mins</p>	<p>The success of this method hinges on the decision as to where to make the cut. Further examples may improve the confidence of students in making appropriate choices.</p> <p>The instructor may need to spend time going through examples to illustrate the idea that there cannot be more than three unknown forces in the cut.</p>
<p>B</p> <p>Load applied to joint R</p> <p>Timing 20 - 35 mins</p>	<p>The students repeat the earlier experiment with the load in a different position on the frame. As a result, the equations used earlier do not apply.</p> <p>The techniques they require are those practised in the previous investigations, but now they will encounter zero force members. The instructor may have to spend time convincing some that, even though the force inside them is zero, these members are still an important part of the frame. This could be a good topic for a research exercise and presentation by more able students.</p> <p>The students revisit the method of joints, using free body diagrams provided in the Student Handout, to generate equations for the new situation and then use them to calculate the theoretical values for the forces in the members. This is a good test of how well they understand the method of joints. Some will certainly need assistance from the instructor.</p>
<p>C</p> <p>Multiple loads</p> <p>Timing 20 - 35 mins</p>	<p>Now, the students add a second load to the frame and measure the resulting forces in the members. Once again, the earlier set of equations are no longer valid. This time, the students create their own free body diagrams and analyse them to produce the equations necessary to work out the sizes and directions of the member forces.</p> <p>The instructions suggest several sets of weights and applied directions. The instructor may choose to distribute these among the groups of students and could add to the number of sets. The results of all the activities could be reported back to the class via student presentations.</p>